

Submersible drainage pumps

for clear water



PERFORMANCE RANGE

- Flow rate up to **400 l/min** (24 m³/h)
- Head up to **27 m**

APPLICATION LIMITS

- **5 m** maximum immersion depth
- Maximum liquid temperature **+40 °C**
- Solids passage:
 - up to **Ø 10 mm** for D6-D8-D10-D15
 - up to **Ø 6 mm** for D18-D20
 - up to **Ø 3 mm** for D30
- Suction level:
 - **23 mm** above ground level for D6-D8-D10-D18-D20
 - **15 mm** above ground level for D15-D30
- **220 mm** minimum immersion depth for continuous service

CONSTRUCTION AND SAFETY STANDARDS

- Complete with **5 m** long power cable
- Float switch for single-phase versions

EN 60335-1
IEC 60335-1
CEI 61-150

EN 60034-1
IEC 60034-1
CEI 2-3



CERTIFICATIONS



INSTALLATION AND USE

Designed to pump **clear or slightly dirty water**, these pumps are suitable for use in domestic, civil and professional applications and in particular for draining flooded areas such as cellars and garages, for draining swimming pools and reservoirs and for the disposal of non-sewage waste water.

These pumps distinguish themselves for their reliability, which can be best appreciated under automatic operating conditions in fixed installations.

PATENTS - TRADE MARKS - MODELS

- Patent pending n° BO2008A000494, BO2008A000496

OPTIONALS AVAILABLE ON REQUEST

- Pumps with a **10 m** long power cable
 - ⇒ N.B. Standard EN 60335-2-41 states that the power cable must be 10 m long for outdoor applications
- Single-phase pumps without float switch
- Other voltages or 60 Hz frequency

GUARANTEE

1 year subject to terms and conditions

CHARACTERISTIC CURVES AND PERFORMANCE DATA

50 Hz n= 2900 1/min

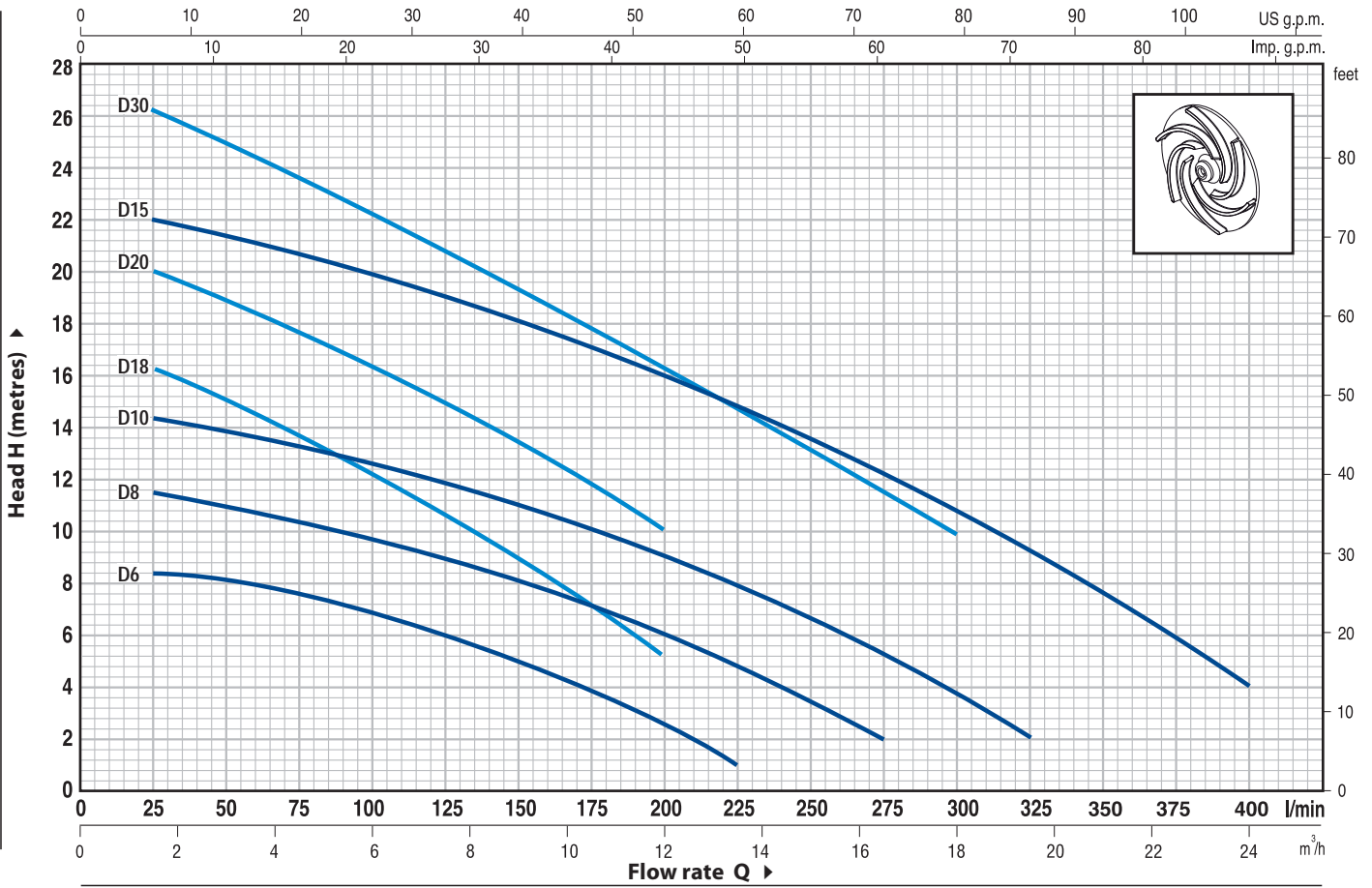

MODEL		POWER		Q	m ³ /h																		
Single-phase	Three-phase	kW	HP		0	1.5	3.0	4.5	6.0	7.5	9.0	10.5	12.0	13.5	15.0	16.5	18.0	19.5	21.0	24.0			
Dm 6	-	0.45	0.60	0	25	50	75	100	125	150	175	200	225	250	275	300	325	350	400				
Dm 8	-	0.55	0.75	9	8.5	8	7.5	6.8	6	5.2	4	2.6	1										
Dm 10	D 10	0.75	1	12	11.5	11	10.5	9.8	9	8.2	7.2	6	4.8	3.5	2								
Dm 15	D 15	1.1	1.5	15	14.5	14	13.2	12.5	11.8	11	10	9	8	6.8	5.4	3.5	2						
Dm 18	-	0.55	0.75	23	22	21.5	20.5	20	19	18	17	16	15	13.5	12	11	9	7.5	4				
Dm 20	D 20	0.75	1	17	16.5	15	13.5	12	10.7	9	7.7	5											
Dm 30	D 30	1.1	1.5	21	20	19	17.5	16	15	13.5	12	10											
				27	26	25	23.5	22	21	19.5	18	16	14.5	13	11.5	10							

Q = Flow rate H = Total manometric head

Tolerance of characteristic curves in compliance with EN ISO 9906 App. A.

POS.	COMPONENT	CONSTRUCTION CHARACTERISTICS
1	PUMP BODY	Cast iron, with threaded port in compliance with ISO 228/1
2	SUCTION FILTER	Stainless steel AISI 304 (with mesh filter for D30)
3	SUCTION PLATE	Stainless steel AISI 304
4	IMPELLER	Technopolymer open type (closed for D30)
5	MOTOR CASING	Stainless steel AISI 304
6	MOTOR CASING PLATE	Stainless steel AISI 304
7	MOTOR SHAFT	Stainless steel EN 10088-3 - 1.4104
8	SHAFT WITH DOUBLE SEAL AND OIL CHAMBER	
	<i>Seal</i>	<i>Shaft</i>
	<i>Model</i>	<i>Diameter</i>
	<i>MG1-14 SIC</i>	\varnothing 14 mm
		<i>Stationary ring</i>
		Ceramic
		<i>Rotational ring</i>
		Silicon carbide
		<i>Elastomer</i>
		NBR
9	LIP SEAL	\varnothing 15 x \varnothing 24 x H 5 mm (\varnothing 16 x \varnothing 24 x H 5 mm for D15, D30)
10	BEARINGS	6203 ZZ / 6203 ZZ
11	CAPACITOR	
	<i>Pump</i>	<i>Capacitance</i>
	<i>Single-phase</i>	(230 V or 240 V) (110 V)
	Dm6	
	Dm8	
	Dm10	20 μ F 450 VL
	Dm18	
	Dm20	
	Dm15	25 μ F 450 VL
	Dm30	-
12	ELECTRIC MOTOR	
	<ul style="list-style-type: none"> - Single-phase 230 V - 50 Hz with thermal overload protector built-in to the winding - Three-phase 400 V - 50 Hz - Insulation: F class - Protection: IP 68 	
13	POWER CABLE	
	5 metre long "H07 RN-F" cable (with Schuko plug on single-phase versions only)	
14	FLOAT SWITCH	
	(only for single-phase versions)	

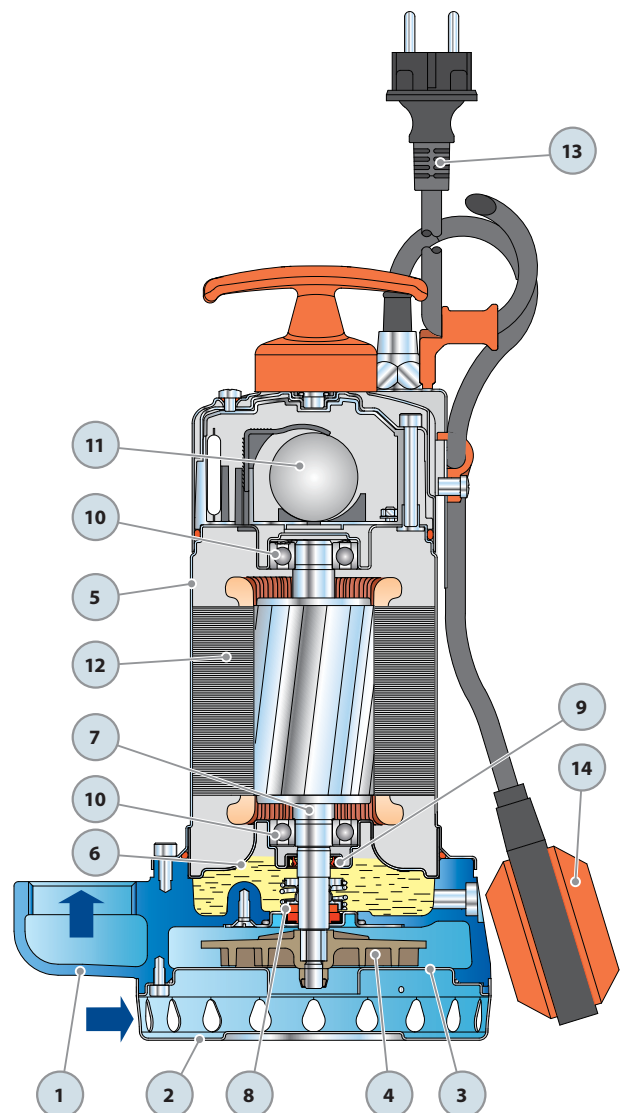

DIMENSIONS AND WEIGHT

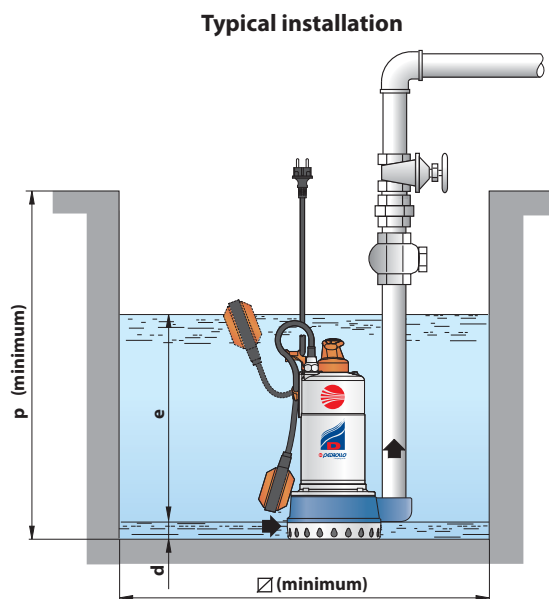
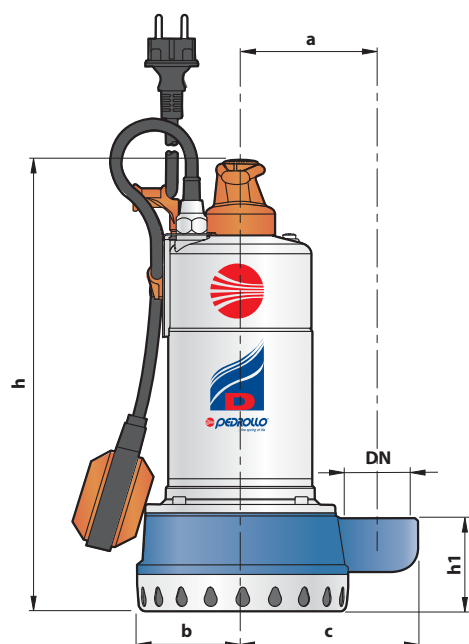

MODEL		PORT DN	DIMENSIONS mm									kg	
Single-phase	Three-phase		a	b	c	h	h1	d	e	p	Ø	1~	3~
Dm 6	-	1½"	105	81	136	352	72	23	variable	500	500	11.7	-
Dm 8	-											11.7	-
Dm 10	D 10											12.7	11.6
Dm 15	D 15		14.7	13.7									
Dm 18	-		11.8	-									
Dm 20	D 20		13.0	11.7									
Dm 30	D 30	110	90	140	371	85	15	15.0	14.0				

ABSORPTION

MODEL	VOLTAGE (single-phase)		
	230 V	240 V	110 V
Single-phase			
Dm 6	2.4 A	2.4 A	5.2 A
Dm 8	3.4 A	3.4 A	6.9 A
Dm 10	5.2 A	5.2 A	10.5 A
Dm 15	7.9 A	7.9 A	-
Dm 18	3.8 A	3.8 A	7.2 A
Dm 20	5.4 A	5.4 A	11.0 A
Dm 30	7.2 A	7.2 A	-

MODEL	VOLTAGE (three-phase)			
	230 V	400 V	240 V	415 V
Three-phase				
D 10	3.6 A	2.1 A	3.6 A	2.1 A
D 15	6.0 A	3.5 A	6.0 A	3.5 A
D 20	3.6 A	2.1 A	3.6 A	2.1 A
D 30	6.0 A	3.5 A	6.0 A	3.5 A

PALLETIZATION

MODEL		GROUPAGE				CONTAINER			
Single-phase	Three-phase	n° pumps	H (mm)	kg		n° pumps	H (mm)	kg	
				1~	3~			1~	3~
Dm 6	-	60	1310	721	-	100	2090	1190	-
Dm 8	-	60	1310	720	-	100	2090	1190	-
Dm 10	D 10	60	1310	780	711	100	2090	1288	1174
Dm 15	D 15	45	1388	678	632	60	1804	898	837
Dm 18	-	60	1310	725	-	100	2090	1197	-
Dm 20	D 20	60	1310	797	720	100	2090	1317	1188
Dm 30	D 30	45	1388	690	647	60	1804	914	857

