



### PERFORMANCE RANGE

- Flow rate up to **160 l/min** (9.6 m<sup>3</sup>/h)
- Head up to **96 m**

### APPLICATION LIMITS

- Manometric suction lift up to **9 m** (HS)
- Liquid temperature between **-10 °C** and **+40 °C**
- Ambient temperature between **-10 °C** and **+40 °C**
- Max. working pressure **10 bar**
- Continuous service **S1**

### CONSTRUCTION AND SAFETY STANDARDS

EN 60335-1  
IEC 60335-1  
CEI 61-150

EN 60034-1  
IEC 60034-1  
CEI 2-3



### CERTIFICATIONS



### INSTALLATION AND USE

Suitable for use with clean water and liquids that are not chemically aggressive towards the materials from which the pump is made. The self-priming JSW pumps are designed to pump water even in cases where air is present. As a result of their reliability and the fact that they are easy to use, they are recommended for use in domestic, civil and industrial applications such as the distribution of water in combination with pressure sets, and for the irrigation of gardens and allotments, etc.

The pump should be installed in an enclosed environment, or at least sheltered from inclement weather.

### PATENTS - TRADE MARKS - MODELS

- Registered Italian model n° 72753

### OPTIONALS AVAILABLE ON REQUEST

- Special mechanical seal
- Other voltages or 60 Hz frequency
- IP55 class protection

### GUARANTEE

1 year subject to terms and conditions

**CHARACTERISTIC CURVES AND PERFORMANCE DATA**

**50 Hz n= 2900 1/min HS= 0 m**

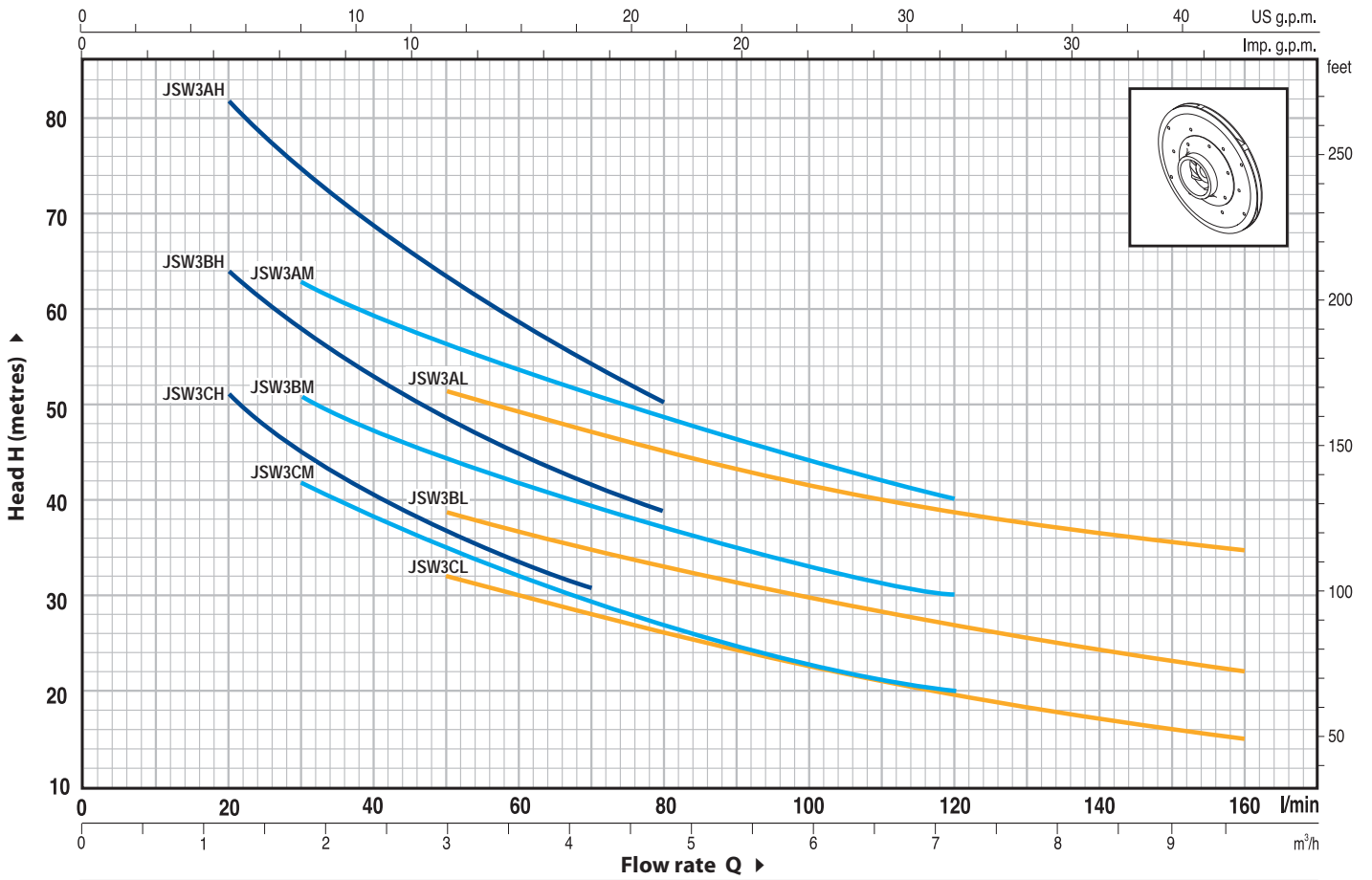

MODEL		POWER		Q	Flow rate																			
Single-phase	Three-phase	kW	HP		m³/h	0	0.6	0.9	1.2	1.5	1.8	2.1	2.4	2.7	3.0	3.6	4.2	4.8	6.0	7.2	8.4	9.6		
				l/min	0	10	15	20	25	30	35	40	45	50	60	70	80	100	120	140	160			
JSWm 3CH	JSW 3CH	1.1	1.5	H metres	64	60	55	51	48	45	42.5	40	39	37	34	31								
JSWm 3BH	JSW 3BH	1.5	2		76	70	67	64	61	58	55.5	53	51	49	45	41	39							
-	JSW 3AH	2.2	3		96	90	86	82	79	75	71.5	69	66	64	58	54	50							
JSWm 3CM	JSW 3CM	1.1	1.5		52	50	48	45	44	42	40	38	37	35	32	29	27	23	20					
JSWm 3BM	JSW 3BM	1.5	2		60	58	56	54	52	51	49	47	46	45	42	39	37	33	30					
-	JSW 3AM	2.2	3		74	70	68	67	65	63	61	59	58	56	54	51	49	44	40					
JSWm 3CL	JSW 3CL	1.1	1.5		42	40	39	38	37	36	35	34	33	32	30	28	26	23	20	17	15			
JSWm 3BL	JSW 3BL	1.5	2		51	48	46	45	44	43	42	41	40	39	37	35	33	30	27	24	22			
-	JSW 3AL	2.2	3		62	60	58	57	56	55	54	53	52	51	49	47	45	42	39	36.5	35			

Q = Flow rate H = Total manometric head HS = Suction height

Tolerance of characteristic curves in compliance with EN ISO 9906 App. A.

**INSTALLATION EXAMPLE**

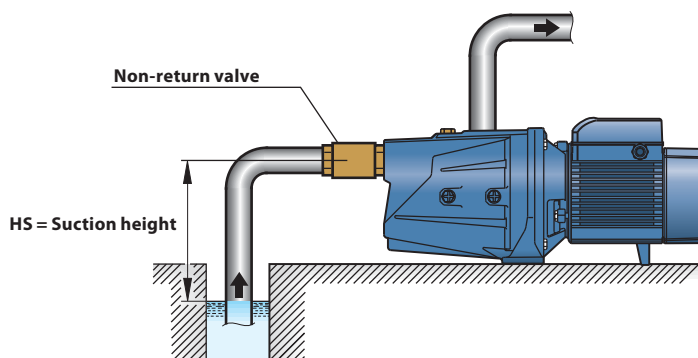

POS.	COMPONENT	CONSTRUCTION CHARACTERISTICS				
1	PUMP BODY	Cast iron, complete with threaded ports in compliance with ISO 228/1				
2	BODY BACKPLATE	Cast iron				
3	NOZZLE ASSEMBLY	Noryl GFN2V				
4	IMPELLER	Brass				
5	MOTOR SHAFT	Stainless steel EN 10088-3 - 1.4104				
6	MECHANICAL SEAL	<b>Seal</b>	<b>Shaft</b>	<b>Materials</b>		
		<i>Model</i>	<i>Diameter</i>	<i>Stationary ring</i>	<i>Rotational ring</i>	<i>Elastomer</i>
		<b>FN-18</b>	<b>Ø 18 mm</b>	Graphite	Ceramic	NBR
7	BEARINGS	<b>6204 ZZ / 6204 ZZ</b>				
8	CAPACITOR	<b>Pump</b>	<b>Capacitance</b>			
		<i>Single-phase</i>	<i>(230 V or 240 V)</i>	<i>(110 V)</i>		
		<b>JSWm 3C</b>	<b>31.5 µF 450 VL</b>	<b>60 µF 250 VL</b>		
		<b>JSWm 3B</b>	<b>45 µF 450 VL</b>	<b>80 µF 250 VL</b>		
9	ELECTRIC MOTOR	<b>JSWm:</b> single-phase 230 V - 50 Hz with thermal overload protector built-in to the winding. <b>JSW:</b> three-phase 230/400 V - 50 Hz. <b>⇒ Pumps fitted with the three-phase motor option offer IE2 (IEC 60034-30) class high performance</b> – Insulation: F class. – Protection: IP 44.				

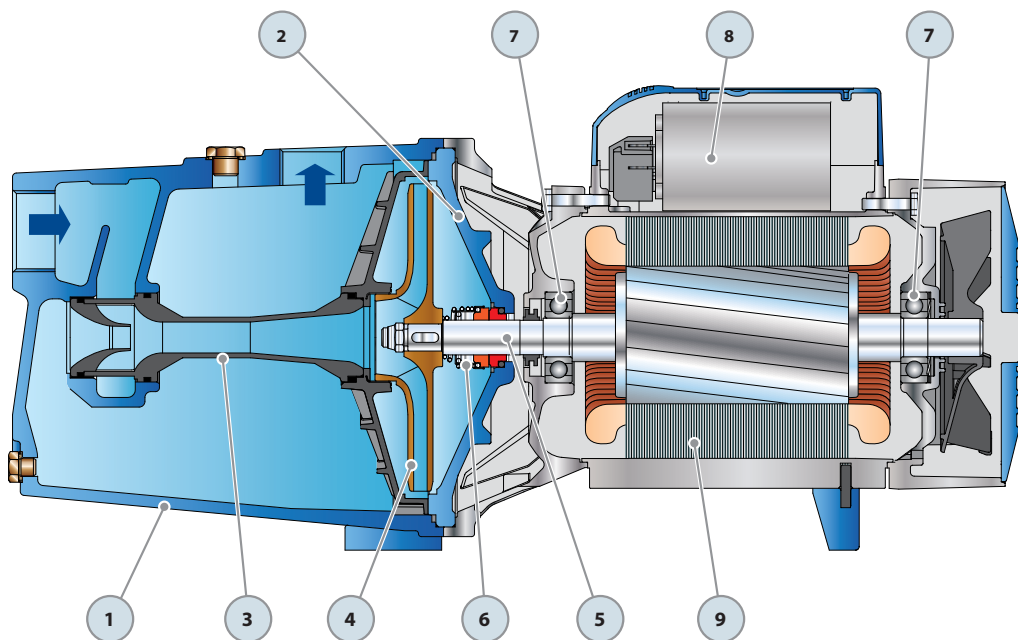

## DIMENSIONS AND WEIGHT

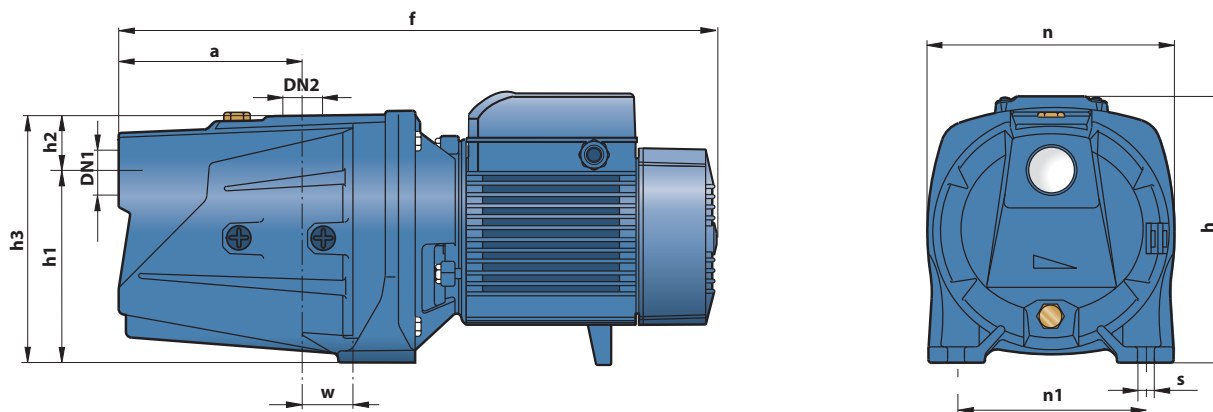

MODEL		PORTS		DIMENSIONS mm										kg	
Single-phase	Three-phase	DN1	DN2	a	f	h	h1	h2	h3	n	n1	w	s	1~	3~
JSWm 3CH	JSW 3CH	1¼"	1"	155	530	242	165	43	208	206	164	30	11	24.9	22.9
JSWm 3BH	JSW 3BH													26.1	25.1
-	JSW 3AH													-	26.4
JSWm 3CM	JSW 3CM													24.9	22.9
JSWm 3BM	JSW 3BM													26.1	25.1
-	JSW 3AM													-	26.4
JSWm 3CL	JSW 3CL													24.9	22.9
JSWm 3BL	JSW 3BL													26.1	25.1
-	JSW 3AL													-	26.4

## ABSORPTION

MODEL	VOLTAGE (single-phase)		
	230 V	240 V	110 V
JSWm 3CH	8.0 A	7.3 A	16.0 A
JSWm 3BH	9.0 A	8.2 A	18.0 A
JSWm 3CM	7.9 A	7.2 A	15.8 A
JSWm 3BM	9.3 A	8.5 A	18.6 A
JSWm 3CL	7.5 A	6.9 A	15.0 A
JSWm 3BL	9.7 A	9.0 A	19.4 A

MODEL	VOLTAGE (three-phase)					
	230 V	400 V	690 V	240 V	415 V	720 V
JSW 3CH	5.5 A	3.2 A	1.8 A	5.3 A	3.1 A	1.8 A
JSW 3BH	6.9 A	4.0 A	2.3 A	6.6 A	3.8 A	2.2 A
JSW 3AH	9.0 A	5.2 A	3.0 A	8.6 A	5.0 A	2.9 A
JSW 3CM	5.9 A	3.4 A	2.0 A	5.7 A	3.3 A	1.9 A
JSW 3BM	7.3 A	4.2 A	2.4 A	7.0 A	4.0 A	2.3 A
JSW 3AM	9.5 A	5.5 A	3.2 A	9.1 A	5.3 A	3.1 A
JSW 3CL	5.5 A	3.2 A	1.8 A	5.3 A	3.1 A	1.8 A
JSW 3BL	7.3 A	4.2 A	2.4 A	7.0 A	4.0 A	2.3 A
JSW 3AL	9.0 A	5.2 A	3.0 A	8.6 A	5.0 A	2.9 A

## PALLETIZATION

MODEL		GROUPAGE				CONTAINER			
Single-phase	Three-phase	n° pumps	H (mm)	kg		n° pumps	H (mm)	kg	
				1~	3~			1~	3~
JSWm 3CH	JSW 3CH	35	1420	890	820	49	1930	1240	1140
JSWm 3BH	JSW 3BH	35	1420	930	900	49	1930	1300	1250
-	JSW 3AH	35	1420	-	941	49	1930	-	1310
JSWm 3CM	JSW 3CM	35	1420	890	820	49	1930	1240	1140
JSWm 3BM	JSW 3BM	35	1420	930	900	49	1930	1300	1250
-	JSW 3AM	35	1420	-	941	49	1930	-	1310
JSWm 3CL	JSW 3CL	35	1420	890	820	49	1930	1240	1140
JSWm 3BL	JSW 3BL	35	1420	930	900	49	1930	1300	1250
-	JSW 3AL	35	1420	-	941	49	1930	-	1310

