



### PERFORMANCE RANGE

- Flow rate up to **50 l/min** (3 m<sup>3</sup>/h)
- Head up to **90 m**

### APPLICATION LIMITS

- Manometric suction lift up to **8 m**
- Liquid temperature between **-10 °C** and **+90 °C**
- Ambient temperature between **-10 °C** and **+40 °C**
- Max. working pressure **10 bar**
- Continuous service **S1**

### CONSTRUCTION AND SAFETY STANDARDS

EN 60034-1  
IEC 60034-1  
CEI 2-3



### CERTIFICATIONS



### INSTALLATION AND USE

Suitable for use with clean water that does not contain abrasive particles and liquids that are not chemically aggressive towards the materials from which the pump is made.

The RYTON and brass pump body construction guarantees against the formation of rust and oxidation. As a result of these characteristics these pumps are suitable for use in industrial applications such as cooling, conditioning and boiler feed.

The pump should be installed in an enclosed environment, or at least sheltered from inclement weather.

### PATENTS - TRADE MARKS - MODELS

- Motor bracket: patented n° IT1243605
- Registered Community Design n° 342159-001

### OPTIONALS AVAILABLE ON REQUEST

- Special mechanical seal
- EN 10088-3 - 1.4401 (AISI 316) stainless steel motor shaft
- Other voltages or 60 Hz frequency
- IP55 class protection

### GUARANTEE

1 year subject to terms and conditions

**CHARACTERISTIC CURVES AND PERFORMANCE DATA**

**50 Hz n= 2900 1/min HS= 0 m**

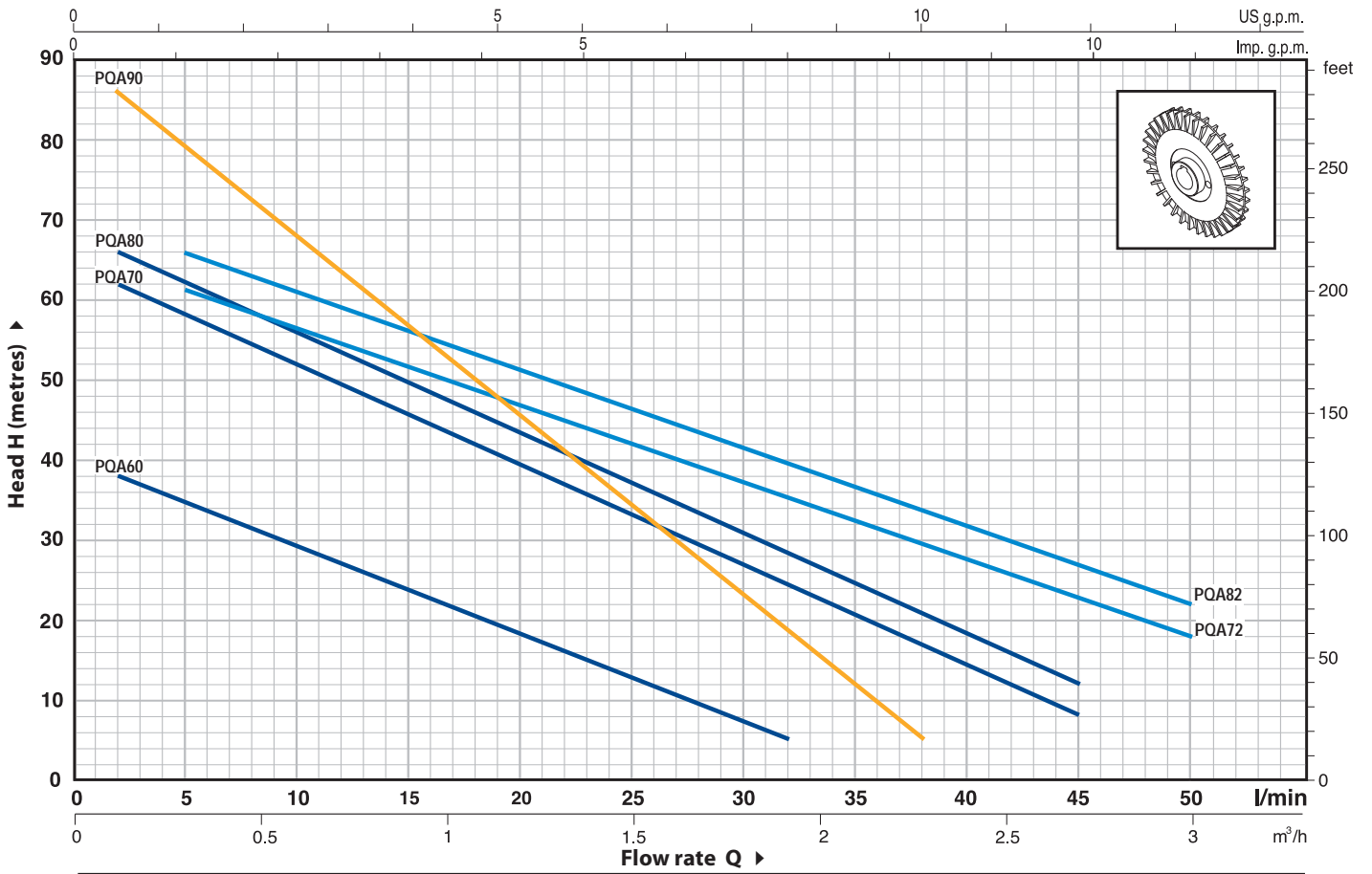

MODEL		POWER		Q	H metres														
Single-phase	Three-phase	kW	HP		m³/h	0	0.1	0.3	0.6	0.9	1.2	1.5	1.8	1.9	2.3	2.7	3.0		
				l/min	0	2	5	10	15	20	25	30	32	38	45	50			
PQAm 60	PQA 60	0.37	0.50	H metres	40	38	35	29	23.5	18	12.5	7	5						
PQAm 70	PQA 70	0.55	0.75		65	62	58	52	45.5	39.5	33	27	24	16.5	8				
PQAm 72	PQA 72	0.55	0.75		65	-	62	57	52	47	42	37.5	35.5	29.5	22.5	18			
PQAm 80	PQA 80	0.75	1		70	66	62	56	49.5	43	37	31	28	20.5	12				
PQAm 82	PQA 82	0.75	1		70	-	66	61	56	51	46	41.5	39.5	37.5	26.5	22			
PQAm 90	PQA 90	0.75	1		90	86	79	68	56.5	45.5	34	23	18.5	5					

Q = Flow rate H = Total manometric head HS = Suction height

Tolerance of characteristic curves in compliance with EN ISO 9906 App. A.

POS.	COMPONENT	CONSTRUCTION CHARACTERISTICS				
1	PUMP BODY	RYTON, complete with threaded metallic port inserts in compliance with ISO 228/1				
2	BODY PLATE	Brass				
3	MOTOR BRACKET	Aluminium with brass insert (patented), reduces the risk of impeller seizure				
4	IMPELLER	Brass, with peripheral radial vanes				
5	MOTOR SHAFT	Stainless steel EN 10088-3 - 1.4104				
6	MECHANICAL SEAL	<i>Seal</i>	<i>Shaft</i>	<i>Materials</i>		
		<i>Model</i>	<i>Diameter</i>	<i>Stationary ring</i>	<i>Rotational ring</i>	<i>Elastomer</i>
		FN-12	Ø 12 mm	Ceramic	Graphite	NBR
7	BEARINGS	<i>Pump</i>	<i>Model</i>			
		PQA 60	6201 ZZ / 6201 ZZ			
		PQA 70-72-80-82-90	6203 ZZ / 6203 ZZ			
8	CAPACITOR	<i>Pump</i>	<i>Capacitance</i>			
		<i>Single-phase</i>	<i>(230 V or 240 V)</i>	<i>(110 V)</i>		
		PQAm 60	10 µF 450 VL	25 µF 250 VL		
		PQAm 70-72	16 µF 450 VL	60 µF 250 VL		
		PQAm 80-82	20 µF 450 VL	60 µF 250 VL		
		PQAm 90	20 µF 450 VL	60 µF 250 VL		
9	ELECTRIC MOTOR	<p><b>PQAm:</b> single-phase 230 V - 50 Hz with thermal overload protector built-in to the winding.</p> <p><b>PQA:</b> three-phase 230/400 V - 50 Hz.</p> <p>⇒ <b>Pumps fitted with the three-phase motor option offer IE2 (IEC 60034-30) class high performance</b></p> <ul style="list-style-type: none"> <li>- Insulation: F class.</li> <li>- Protection: IP 44.</li> </ul>				

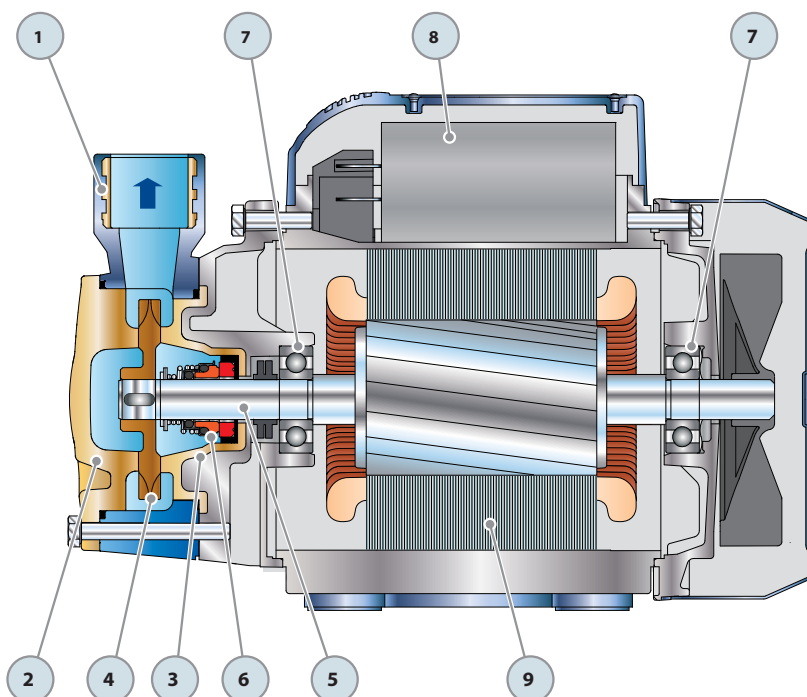

## DIMENSIONS AND WEIGHT

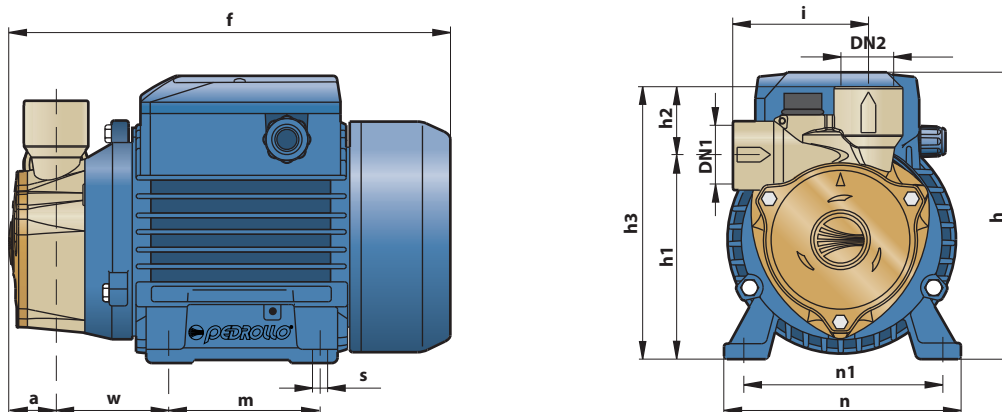

MODEL		PORTS		DIMENSIONS mm												kg	
Single-phase	Three-phase	DN1	DN2	a	f	h	h1	h2	h3	i	m	n	n1	w	s	1~	3~
PQAm 60	PQA 60	½"	½"	25	226	152	103	33	136	72.5	80	120	100	55	7	4.8	4.8
PQAm 70	PQA 70						116.5	32.5	149							9.4	8.4
PQAm 72	PQA 72	1"	1"	28	258	179	121	30	151	83	90	138	112	62	7	9.5	8.5
PQAm 80	PQA 80	½"	½"				116.5	32.5	149	72.5						9.4	8.4
PQAm 82	PQA 82	1"	1"	28	258	179	121	30	151	83	90	138	112	62	7	9.5	8.5
PQAm 90	PQA 90	½"	½"					35	156	76						9.5	8.5

## ABSORPTION

MODEL	VOLTAGE (single-phase)		
	230 V	240 V	110 V
Single-phase			
PQAm 60	2.5 A	2.4 A	5.2 A
PQAm 70	6.2 A	5.5 A	10.8 A
PQAm 72	6.2 A	5.5 A	10.8 A
PQAm 80	6.3 A	5.5 A	10.8 A
PQAm 82	6.3 A	5.5 A	10.8 A
PQAm 90	5.6 A	5.1 A	11.5 A

MODEL	VOLTAGE (three-phase)			
	230 V	400 V	240 V	415 V
Three-phase				
PQA 60	2.0 A	1.15 A	1.9 A	1.1 A
PQA 70	4.2 A	2.4 A	3.7 A	2.2 A
PQA 72	4.2 A	2.4 A	3.7 A	2.2 A
PQA 80	4.2 A	2.4 A	3.7 A	2.2 A
PQA 82	4.2 A	2.4 A	3.7 A	2.2 A
PQA 90	4.2 A	2.4 A	3.8 A	2.2 A

## PALLETIZATION

MODEL		GROUPAGE				CONTAINER			
Single-phase	Three-phase	n° pumps	H (mm)	kg		n° pumps	H (mm)	kg	
				1~	3~			1~	3~
PQAm 60	PQA 60	192	1490	940	940	264	1990	1290	1290
PQAm 70	PQA 70	120	1310	1150	1030	180	1900	1710	1530
PQAm 72	PQA 72	120	1310	1160	1040	180	1900	1730	1550
PQAm 80	PQA 80	120	1310	1150	1030	180	1900	1710	1530
PQAm 82	PQA 82	120	1310	1160	1040	180	1900	1730	1550
PQAm 90	PQA 90	120	1310	1160	1040	180	1900	1730	1550

