



PERFORMANCE RANGE

- Flow rate up to **90 l/min** (5.4 m³/h)
- Head up to **100 m**

APPLICATION LIMITS

- Manometric suction lift up to **8 m**
- Liquid temperature between **-10 °C** and **+90 °C**
- Ambient temperature between **-10 °C** and **+40 °C**
- Max. working pressure:
 - **6 bar** for PQ 60-65
 - **10 bar** for PQ 70-80-81-90-100-200-300
- Continuous service **S1**

CONSTRUCTION AND SAFETY STANDARDS

EN 60034-1
IEC 60034-1
CEI 2-3



CERTIFICATIONS



INSTALLATION AND USE

Suitable for use with clean water that does not contain abrasive particles and liquids that are not chemically aggressive towards the materials from which the pump is made.

The hydraulic characteristics of these pumps, coupled with their compactness, makes them suitable for use in both domestic and industrial applications.

The pump should be installed in an enclosed environment, or at least sheltered from inclement weather.

PATENTS - TRADE MARKS - MODELS

- Motor bracket: patent n° IT1243605
- Registered Italian model n° 72753

OPTIONALS AVAILABLE ON REQUEST

- Special mechanical seal
- EN 10088-3 - 1.4401 (AISI 316) stainless steel motor shaft
- Other voltages or 60 Hz frequency
- IP55 class protection

GUARANTEE

1 year subject to terms and conditions

CHARACTERISTIC CURVES AND PERFORMANCE DATA

50 Hz n= 2900 1/min HS= 0 m

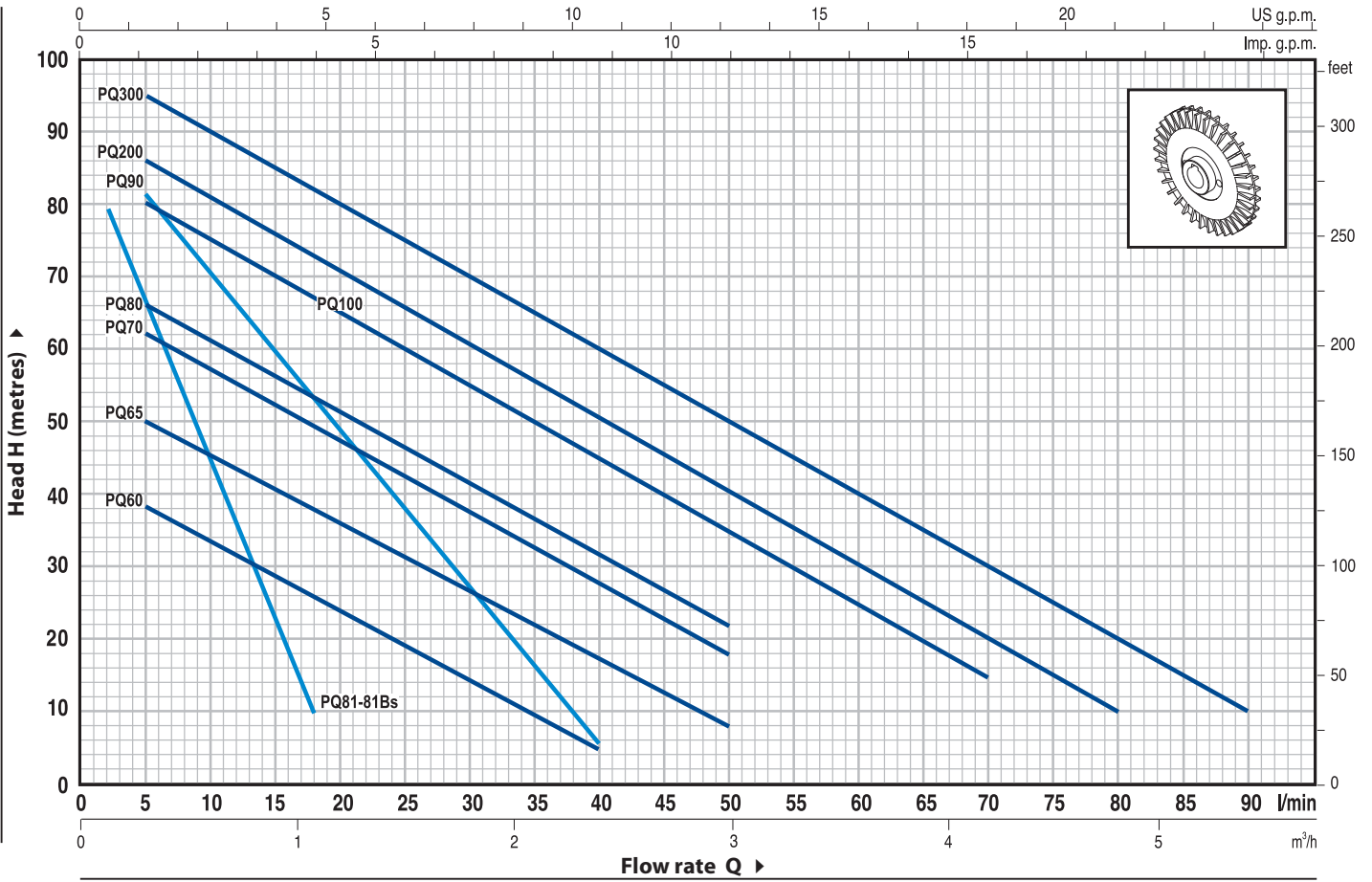

MODEL		POWER		Q	Flow rate																
Single-phase	Three-phase	kW	HP		m³/h	0	0.3	0.6	0.9	1.2	1.5	1.8	2.1	2.4	3.0	3.6	4.2	4.8	5.4		
				l/min	0	5	10	15	20	25	30	35	40	50	60	70	80	90			
PQm 60	PQ 60	0.37	0.50	H metres	40	38	33.5	29	24	19.5	15	10	5								
PQm 65	PQ 65	0.50	0.70		55	50	45.5	40.5	36	31	27	22	17	8							
PQm 70	PQ 70	0.60	0.85		65	62	57	52	47	42	37	32	27	18							
PQm 80	PQ 80	0.75	1		70	66	61	56	51	46	41	36.5	31	22							
PQm 90	PQ 90	0.75	1		90	82	71	60	49	38	27	17	5								
PQm 100	PQ 100	1.1	1.5		85	80	75	70	65	60	55	50	45	35	25	15					
PQm 200	PQ 200	1.5	2		90	86	81	76	71	65.5	60	55	50	40	30	20	10				
-	PQ 300	2.2	3		100	95	90	85	80	75	70	65	60	50	40	30	20	10			

MODEL		POWER		Q	Flow rate									
Single-phase	Three-phase	kW	HP		m³/h	0	0.12	0.24	0.36	0.48	0.60	0.72	0.84	0.96
				l/min	0	2	4	6	8	10	12	14	16	18
PQm 81	PQ 81	0.50	0.70	H metres	90	80	71	63	54	45	37	28	19	10
PQm 81-Bs	PQ 81-Bs	0.50	0.70		90	80	71	63	54	45	37	28	19	10

⇒ PQ 81 Bs= version with brass pump body

Q = Flow rate H = Total manometric head HS = Suction height

Tolerance of characteristic curves in compliance with EN ISO 9906 App. A.

POS.	COMPONENT	CONSTRUCTION CHARACTERISTICS					
1	PUMP BODY	Cast iron (brass for PQ 81-Bs), complete with threaded ports in compliance with ISO 228/1					
2	MOTOR BRACKET	Aluminium with brass insert (patented), reduces the risk of impeller seizure					
3	IMPELLER	Brass, with peripheral radial vanes					
4	MOTOR SHAFT	Stainless steel EN 10088-3 - 1.4104					
5	MECHANICAL SEAL	Pump	Seal	Shaft	Materials		
		<i>Model</i>	<i>Model</i>	<i>Diameter</i>	<i>Stationary ring</i>	<i>Rotational ring</i>	<i>Elastomer</i>
		PQ 60-65	AR-12	Ø 12 mm	Ceramic	Graphite	NBR
		PQ 70-80-81-81Bs-90	FN-12	Ø 12 mm	Ceramic	Graphite	NBR
PQ 100-200-300	FN-14	Ø 14 mm	Graphite	Ceramic	NBR		
6	BEARINGS	Pump	Model				
		PQ 60-65-81-81Bs	6201 ZZ / 6201 ZZ				
		PQ 70-80-90	6203 ZZ / 6203 ZZ				
		PQ 100-200-300	6204 ZZ / 6204 ZZ				
7	CAPACITOR	Pump	Capacitance				
		<i>Single-phase</i>	<i>(230 V or 240 V)</i>		<i>(110 V)</i>		
		PQm 60	10 µF 450 VL	25 µF 250 VL			
		PQm 65	14 µF 450 VL	30 µF 250 VL			
		PQm 70	16 µF 450 VL	60 µF 300 VL			
		PQm 80	20 µF 450 VL	60 µF 300 VL			
		PQm 81 - 81Bs	14 µF 450 VL	30 µF 250 VL			
		PQm 90	20 µF 450 VL	60 µF 300 VL			
		PQm 100	31.5 µF 450 VL	60 µF 250 VL			
		PQm 200	45 µF 450 VL	80 µF 250 VL			
8	ELECTRIC MOTOR	PQm: single-phase 230 V - 50 Hz with thermal overload protector built-in to the winding.					
		PQ: three-phase 230/400 V - 50 Hz.					
<p>➔ Pumps fitted with the three-phase motor option offer IE2 (IEC 60034-30) class high performance</p> <ul style="list-style-type: none"> - Insulation: F class. - Protection: IP 44. 							

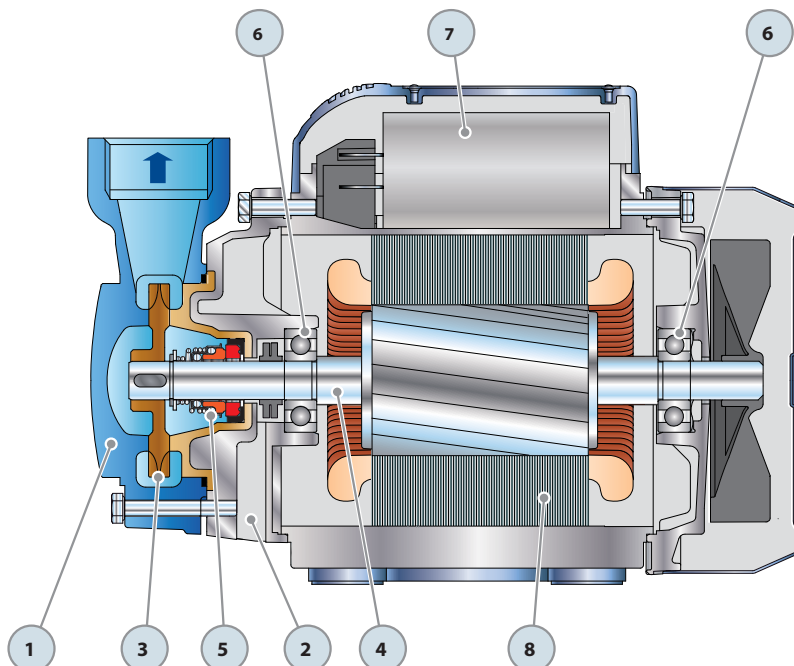

DIMENSIONS AND WEIGHT

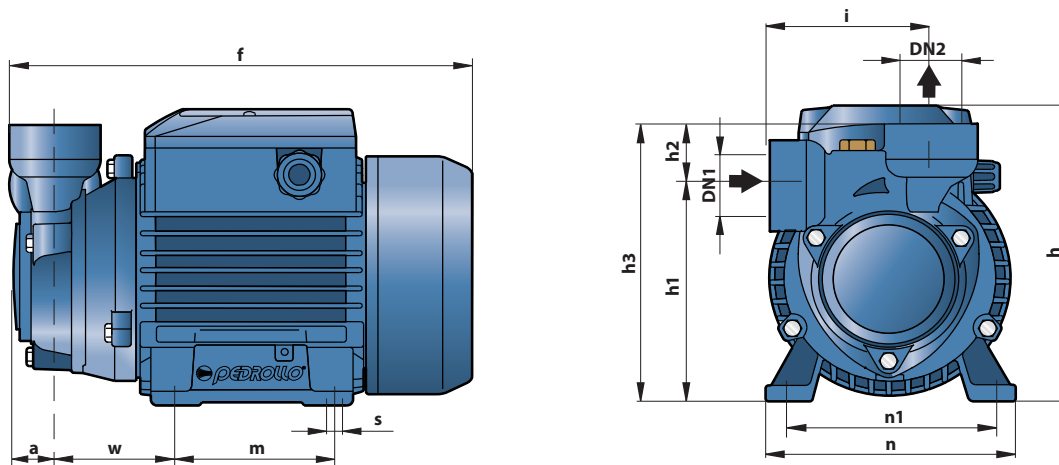

MODEL		PORTS		DIMENSIONS mm											kg		
Single-phase	Three-phase	DN1	DN2	a	f	h	h1	h2	h3	i	m	n	n1	w	s	1~	3~
PQm 60	PQ 60	1"	1"	22	225	152	108	30	138	78	80	120	100	55	7	5.1	5.1
PQm 65	PQ 65						113		143					57		6.6	6.1
PQm 70	PQ 70						121		151					62		9.7	9.0
PQm 80	PQ 80						126		153					62		9.7	9.0
PQm 81	PQ 81	1/2"	1/2"	18	220	152	119	23	141	71	80	120	100	58		6.6	6.2
PQm 81-Bs	PQ 81-Bs	1/2"	1/2"	18	220	152	119	23	141	71	80	120	100	58		6.5	6.1
PQm 90	PQ 90	3/4"	3/4"	22	255	180	126	27	153	84	90	138	112	62		9.9	8.8
PQm 100	PQ 100	1"	1"	25	318	212	140	30	170	89	100	164	125	85	9	14.1	12.2
PQm 200	PQ 200															15.2	14.1
-	PQ 300															-	15.2

ABSORPTION

MODEL	VOLTAGE (single-phase)		
	230 V	240 V	110 V
Single-phase	230 V	240 V	110 V
PQm 60	2.6 A	2.4 A	5.2 A
PQm 65	3.7 A	3.4 A	7.4 A
PQm 70	5.2 A	4.8 A	10.8 A
PQm 80	5.2 A	4.8 A	10.8 A
PQm 81	3.4 A	2.7 A	5.8 A
PQm 81-Bs	3.4 A	2.7 A	5.8 A
PQm 90	5.6 A	5.1 A	11.5 A
PQm 100	9.0 A	8.2 A	18.0 A
PQm 200	12.0 A	11.0 A	24.0 A

MODEL	VOLTAGE (three-phase)				
	230 V	400 V	690 V	240 V	415 V
Three-phase	230 V	400 V	690 V	240 V	415 V
PQ 60	2.0 A	1.15 A	-	1.9 A	1.1 A
PQ 65	3.0 A	1.7 A	-	2.8 A	1.6 A
PQ 70	3.8 A	2.2 A	-	3.3 A	1.9 A
PQ 80	3.8 A	2.2 A	-	3.3 A	1.9 A
PQm 81	2.2 A	1.3 A	-	2.0 A	1.15 A
PQm 81-Bs	2.2 A	1.3 A	-	2.0 A	1.15 A
PQ 90	4.2 A	2.4 A	-	3.8 A	2.2 A
PQ 100	6.3 A	3.6 A	2.05 A	5.7 A	3.3 A
PQ 200	7.6 A	4.4 A	2.5 A	7.0 A	4.0 A
PQ 300	9.3 A	5.4 A	3.15 A	8.7 A	5.0 A

PALLETIZATION

MODEL		GROUPAGE				CONTAINER			
Single-phase	Three-phase	n° pumps	H (mm)	kg		n° pumps	H (mm)	kg	
				1~	3~			1~	3~
PQm 60	PQ 60	240	1440	1250	1250	270	1600	1400	1400
PQm 65	PQ 65	240	1440	1600	1490	270	1600	1800	1670
PQm 70	PQ 70	120	1270	1190	1100	180	1850	1770	1640
PQm 80	PQ 80	120	1280	1190	1100	180	1850	1770	1640
PQm 81	PQ 81	192	1460	1290	1210	264	1960	1760	1660
PQm 81-Bs	PQ 81-Bs	192	1460	1270	1190	264	1960	1740	1630
PQm 90	PQ 90	120	1280	1210	1080	180	1850	1800	1610
PQm 100	PQ 100	72	1510	1040	900	96	1970	1380	1190
PQm 200	PQ 200	72	1510	1120	1040	96	1970	1480	1380
-	PQ 300	72	1510	-	1120	96	1970	-	1480

