

PRO-NGA

Stainless steel pump with open impeller



PERFORMANCE RANGE

- Flow rate up to **350 l/min** (21 m³/h)
- Head up to **20 m**

APPLICATION LIMITS

- Manometric suction lift up to **7 m**
- Liquid temperature between **-10 °C** and **+90 °C**
- Ambient temperature between **-10 °C** and **+40 °C**
- Max. working pressure **6 bar**
- Passage of suspended solids up to **Ø 10 mm**
- Continuous service **S1**

CONSTRUCTION AND SAFETY STANDARDS

EN 60034-1
IEC 60034-1
CEI 2-3



CERTIFICATIONS



INSTALLATION AND USE

Suitable for use with clean water and liquids that are not chemically aggressive towards the materials from which the pump is made. The open impeller design allows **liquids containing relatively high levels of impurities** to be pumped without the risk of the impeller clogging. All of the components in contact with the pumped liquid are constructed in stainless steel AISI 316. As a result of these characteristics the PRO-NGA series pumps find specific use in assemblies for washing fruit, vegetables, fish and shellfish, in industrial assemblies for washing metallic objects and glass containers, as well as for the circulation of cooling liquids. The pump should be installed in an enclosed environment, or at least sheltered from inclement weather.

OPTIONALS AVAILABLE ON REQUEST

- Special mechanical seal
- Other voltages or 60 Hz frequency

GUARANTEE

1 year subject to terms and conditions

CHARACTERISTIC CURVES AND PERFORMANCE DATA

50 Hz n= 2900 1/min HS= 0 m

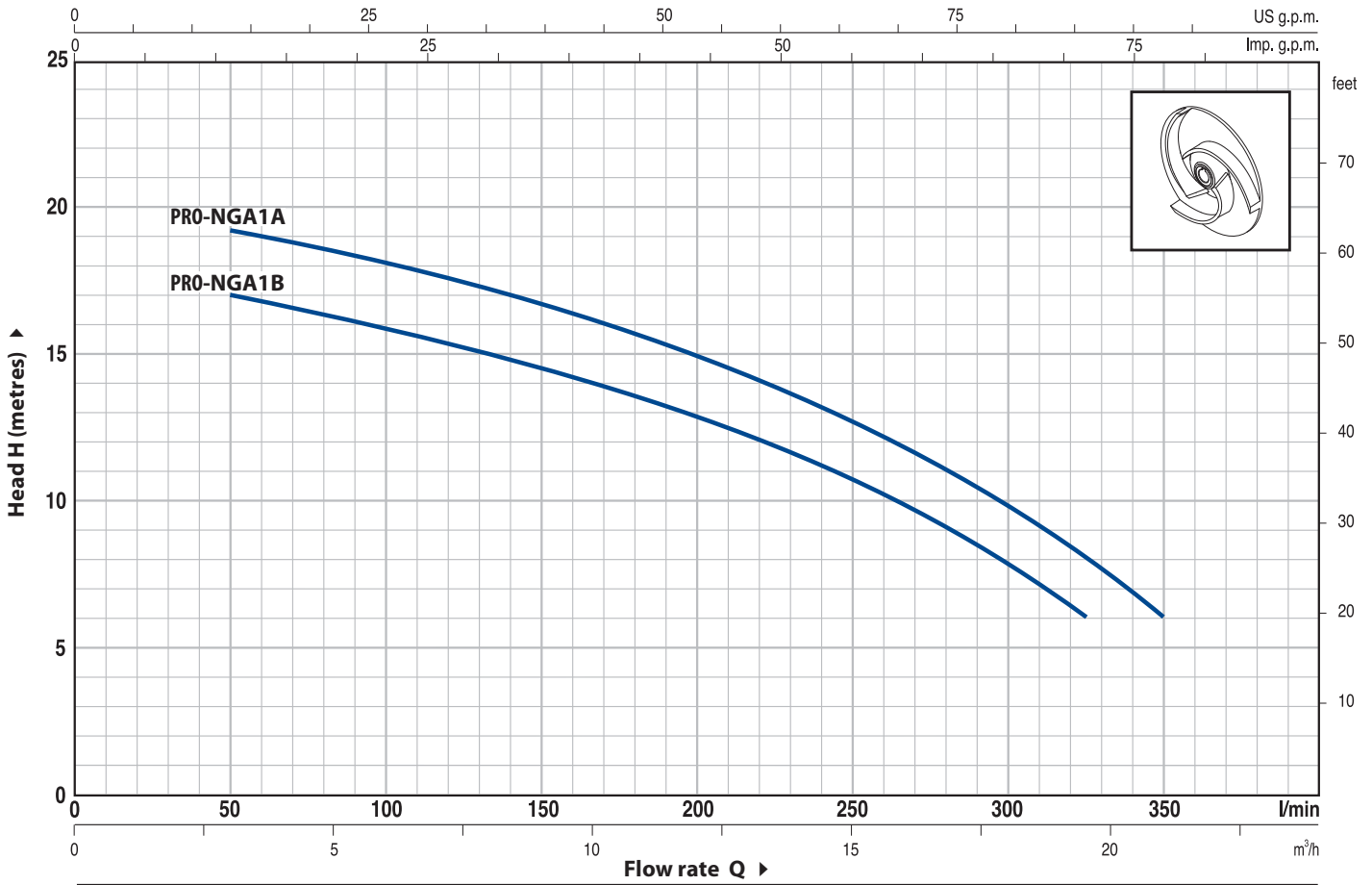

MODEL		POWER		Q	Flow rate											
Single-phase	Three-phase	kW	HP		m ³ /h	0	3	6	9	12	15	18	19.5	21		
PRO-NGAm 1B	PRO-NGA 1B	0.55	0.75	l/min	0	50	100	150	200	250	300	325	350			
				H metres	18	17	16	14.5	13	10.5	8	6				
PRO-NGAm 1A	PRO-NGA 1A	0.75	1		20	19.5	18	16.5	15	12.5	10	8	6			

Q = Flow rate H = Total manometric head HS = Suction height

Tolerance of characteristic curves in compliance with EN ISO 9906 App. A.

POS.	COMPONENT	CONSTRUCTION CHARACTERISTICS				
1	PUMP BODY	Stainless steel AISI 316, complete with threaded ports in compliance with ISO 228/1				
2	BODY BACKPLATE	Stainless steel AISI 316				
3	IMPELLER	Open impeller in stainless steel 316				
4	MOTOR SHAFT	Stainless steel AISI 316				
5	MECHANICAL SEAL	<i>Seal</i>	<i>Shaft</i>	<i>Materials</i>		
		<i>Model</i>	<i>Diameter</i>	<i>Stationary ring</i>	<i>Rotational ring</i>	<i>Elastomer</i>
		AR-14S	Ø 14 mm	Ceramic	Graphite	Viton
6	BEARINGS	6203 ZZ / 6203 ZZ				
7	CAPACITOR	<i>Pump</i>	<i>Capacitance</i>			
		<i>Single-phase</i>	<i>(230 V or 240 V)</i>	<i>(110 V)</i>		
		PRO-NGAm 1B	16 µF 450 VL	60 µF 300 VL		
		PRO-NGAm 1A	20 µF 450 VL	60 µF 300 VL		

8 ELECTRIC MOTOR **PRO-NGAm:** single-phase 230 V - 50 Hz with thermal overload protector built-in to the winding.
PRO-NGA: three-phase 230/400 V - 50 Hz.
⇒ Pumps fitted with the three-phase motor option offer IE2 (IEC 60034-30) class high performance
 – Insulation: F class.
 – Protection: IP 44.

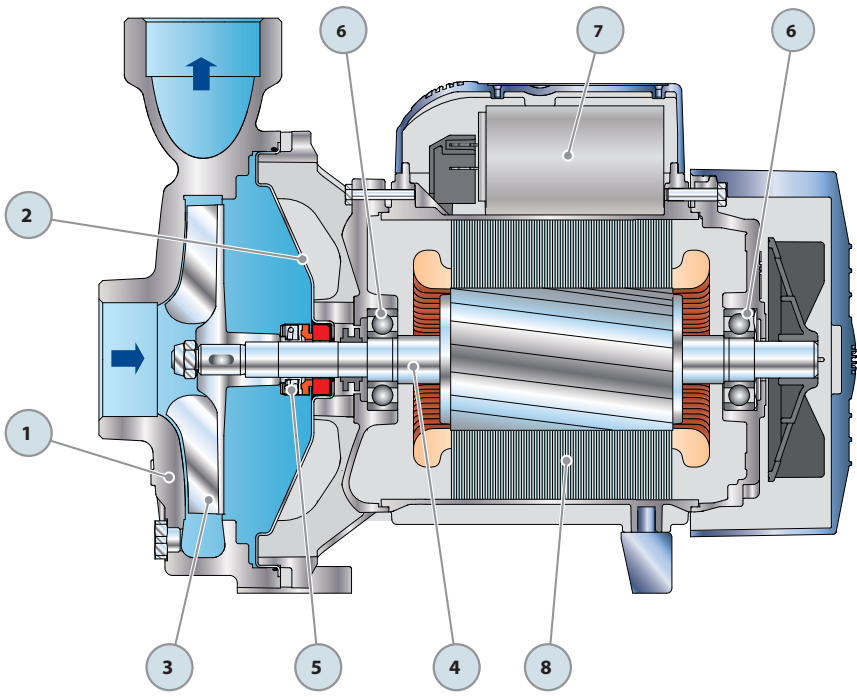

DIMENSIONS AND WEIGHT

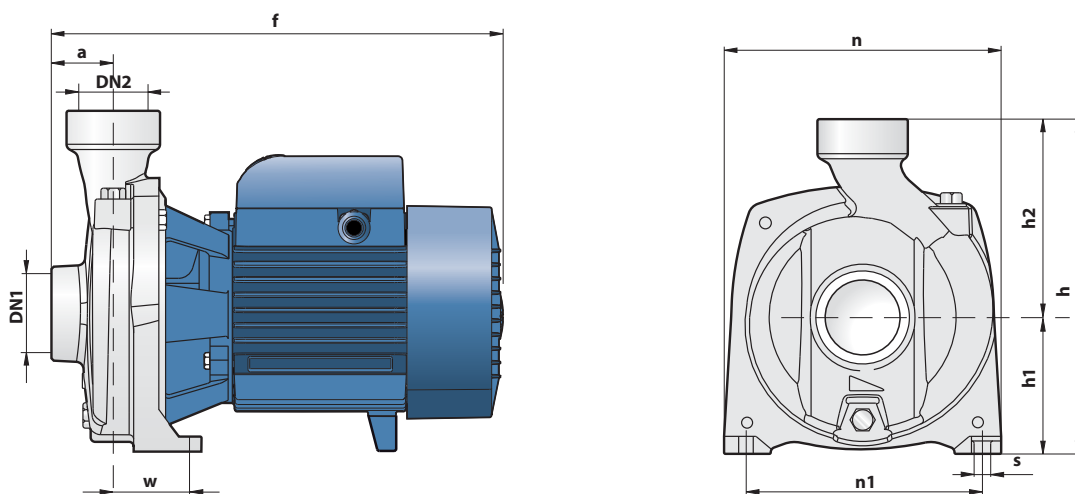

MODEL		PORTS		DIMENSIONS mm									kg	
Single-phase	Three-phase	DN1	DN2	a	f	h	h1	h2	n	n1	w	s	1~	3~
PRO-NGAm 1B	PRO-NGA 1B	1½"	1½"	41	297	227	92	135	190	160	50	10	13.0	11.9
PRO-NGAm 1A	PRO-NGA 1A												13.1	12.0

ABSORPTION

MODEL	VOLTAGE (single-phase)		
	230 V	240 V	110 V
Single-phase	230 V	240 V	110 V
PRO-NGAm 1B	5.6 A	5.3 A	11.2 A
PRO-NGAm 1A	6.2 A	6.0 A	12.0 A

MODEL	VOLTAGE (three-phase)					
	230 V	400 V	690 V	240 V	415 V	720 V
Three-phase	230 V	400 V	690 V	240 V	415 V	720 V
PRO-NGA 1B	3.3 A	1.9 A	1.1 A	3.2 A	1.85 A	1.1 A
PRO-NGA 1A	3.6 A	2.1 A	1.2 A	3.5 A	2.0 A	1.2 A

PALLETIZATION

MODEL		GROUPAGE				CONTAINER			
		n° pumps	H (mm)	kg		n° pumps	H (mm)	kg	
Single-phase	Three-phase			1~	3~			1~	3~
PRO-NGAm 1B	PRO-NGA 1B	70	1415	930	850	112	2180	1480	1350
PRO-NGAm 1A	PRO-NGA 1A	70	1415	940	860	112	2180	1490	1360

