



### PERFORMANCE RANGE

- Flow rate up to **350 l/min** (21 m<sup>3</sup>/h)
- Head up to **20 m**

### APPLICATION LIMITS

- Manometric suction lift up to **7 m**
- Liquid temperature between **-10 °C** and **+90 °C**  
(up to +40 for the version with the technopolymer impeller)
- Ambient temperature between **-10 °C** and **+40 °C**
- Max. working pressure **6 bar**
- Passage of suspended solids up to **Ø 10 mm**
- Continuous service **S1**

### CONSTRUCTION AND SAFETY STANDARDS

EN 60034-1  
IEC 60034-1  
CEI 2-3



### CERTIFICATIONS



### INSTALLATION AND USE

Suitable for use with liquids that are not chemically aggressive towards the materials from which the pump is made.

The open impeller design allows **liquids containing relatively high levels of impurities** to be pumped without the risk of the impeller clogging. As a result of these characteristics the NGA series pumps are used specifically in industry and for transferring water from canals, rivers, reservoirs, tanks, etc.

The pump should be installed in an enclosed environment, or at least sheltered from inclement weather.

### OPTIONALS AVAILABLE ON REQUEST

- Pump with technopolymer impeller
- Special mechanical seal
- Other voltages or 60 Hz frequency

### GUARANTEE

1 year subject to terms and conditions

**CHARACTERISTIC CURVES AND PERFORMANCE DATA**

**50 Hz n= 2900 1/min HS= 0 m**

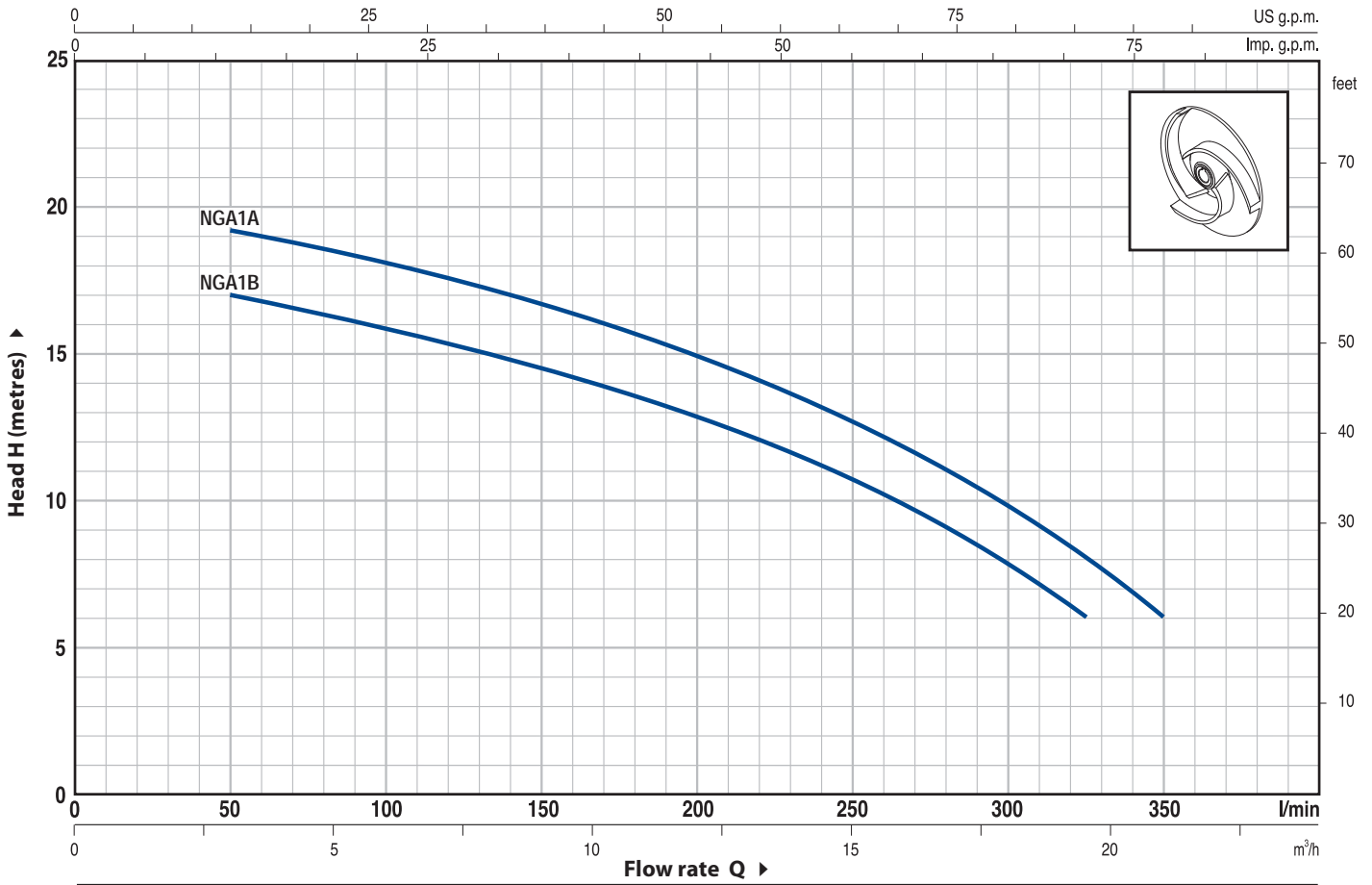

MODEL		POWER		Q	0	3	6	9	12	15	18	19.5	21
Single-phase	Three-phase	kW	HP		0	50	100	150	200	250	300	325	350
<b>NGAm 1B</b>	<b>NGA 1B</b>	0.55	0.75	H metres	18	17	16	14.5	13	10.5	8	6	
<b>NGAm 1A</b>	<b>NGA 1A</b>	0.75	1		20	19.5	18	16.5	15	12.5	10	8	6

Q = Flow rate H = Total manometric head HS = Suction height

Tolerance of characteristic curves in compliance with EN ISO 9906 App. A.

POS.	COMPONENT	CONSTRUCTION CHARACTERISTICS				
1	PUMP BODY	Cast iron, complete with threaded ports in compliance with ISO 228/1				
2	BODY BACKPLATE	Stainless steel AISI 304				
3	IMPELLER	Open impeller in stainless steel 316				
4	MOTOR SHAFT	Stainless steel EN 10088-3 - 1.4104				
5	MECHANICAL SEAL	<i>Seal</i>	<i>Shaft</i>	<i>Materials</i>		
		<i>Model</i>	<i>Diameter</i>	<i>Stationary ring</i>	<i>Rotational ring</i>	<i>Elastomer</i>
		AR-14	Ø 14 mm	Ceramic	Graphite	NBR
6	BEARINGS	6203 ZZ / 6203 ZZ				
7	CAPACITOR	<i>Pump</i>	<i>Capacitance</i>			
		<i>Single-phase</i>	<i>(230 V or 240 V)</i>		<i>(110 V)</i>	
		NGAm 1B	16 µF 450 VL		60 µF 300 VL	
		NGAm 1A	20 µF 450 VL		60 µF 300 VL	
8	ELECTRIC MOTOR	<p><b>NGAm:</b> single-phase 230 V - 50 Hz with thermal overload protector built-in to the winding.</p> <p><b>NGA:</b> three-phase 230/400 V - 50 Hz.</p> <p>⇒ <b>Pumps fitted with the three-phase motor option offer IE2 (IEC 60034-30) class high performance</b></p> <ul style="list-style-type: none"> <li>- Insulation: F class.</li> <li>- Protection: IP 44.</li> </ul>				

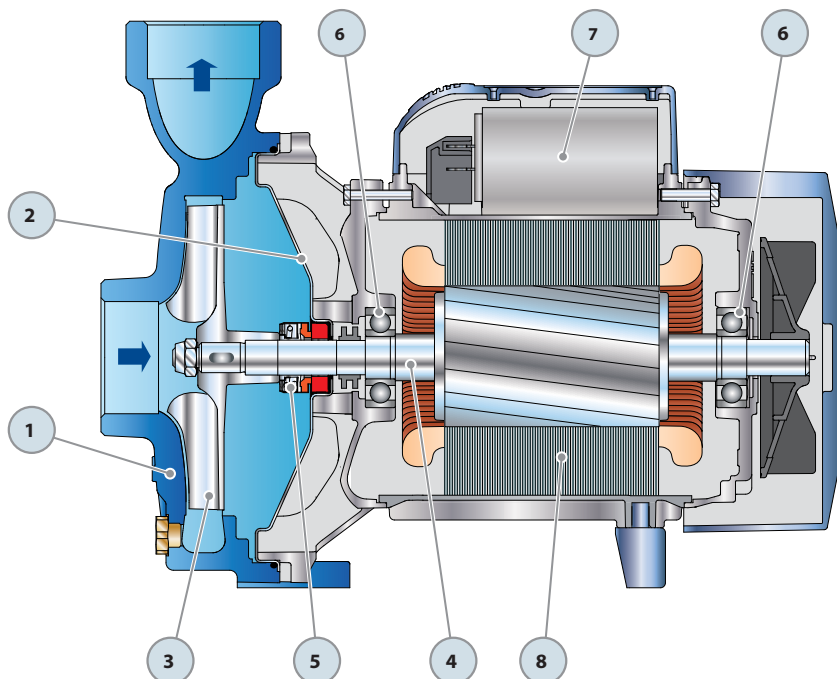

## DIMENSIONS AND WEIGHT

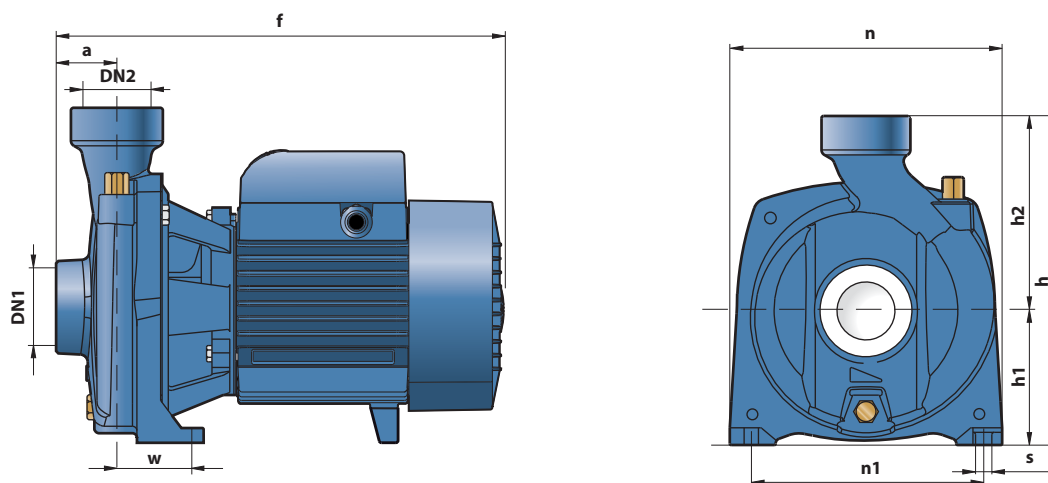

MODEL		PORTS		DIMENSIONS mm									kg	
Single-phase	Three-phase	DN1	DN2	a	f	h	h1	h2	n	n1	w	s	1~	3~
NGAm 1B	NGA 1B	1½"	1½"	41	297	227	92	135	190	160	50	10	12.7	11.8
NGAm 1A	NGA 1A												12.8	11.9

## ABSORPTION

MODEL	VOLTAGE (single-phase)		
Single-phase	230 V	240 V	110 V
NGAm 1B	5.6 A	5.3 A	11.2 A
NGAm 1A	6.2 A	6.0 A	12.0 A

MODEL	VOLTAGE (three-phase)					
Three-phase	230 V	400 V	690 V	240 V	415 V	720 V
NGA 1B	3.3 A	1.9 A	1.1 A	3.2 A	1.85 A	1.1 A
NGA 1A	3.7 A	2.1 A	1.2 A	3.7 A	2.1 A	1.2 A

## PALLETIZATION

MODEL		GROUPAGE				CONTAINER			
Single-phase	Three-phase	n° pumps	H (mm)	kg		n° pumps	H (mm)	kg	
				1~	3~			1~	3~
NGAm 1B	NGA 1B	70	1415	910	840	112	2180	1440	1340
NGAm 1A	NGA 1A	70	1415	920	850	112	2180	1450	1350

