



PERFORMANCE RANGE

- Flow rate up to **900 l/min** (54 m³/h)
- Head up to **74 m**

APPLICATION LIMITS

- Manometric suction lift up to **7 m**
- Liquid temperature between **-10 °C** and **+90 °C**
- Ambient temperature between **-10 °C** and **+40 °C**
- Max. working pressure **10 bar**
- Continuous service **S1**

CONSTRUCTION AND SAFETY STANDARDS

EN 60034-1
IEC 60034-1
CEI 2-3



CERTIFICATIONS



INSTALLATION AND USE

Suitable for use with clean water and liquids that are not chemically aggressive towards the materials from which the pump is made. As a result of their reliability and the fact that they are easy to use, these pumps are widely used in civil, agricultural and industrial applications such as for supplying water, in conditioning and cooling systems, for irrigation, etc. The pump should be installed in an enclosed environment, or at least sheltered from inclement weather.

PATENTS - TRADE MARKS - MODELS

- Registered Italian model n° 72753

OPTIONALS AVAILABLE ON REQUEST

- Special mechanical seal
- EN 10088-3 - 1.4401 (AISI 316) stainless steel motor shaft
- Other voltages or 60 Hz frequency
- IP55 class protection

GUARANTEE

1 year subject to terms and conditions

PERFORMANCE RANGE

50 Hz n= 2900 1/min HS= 0 m

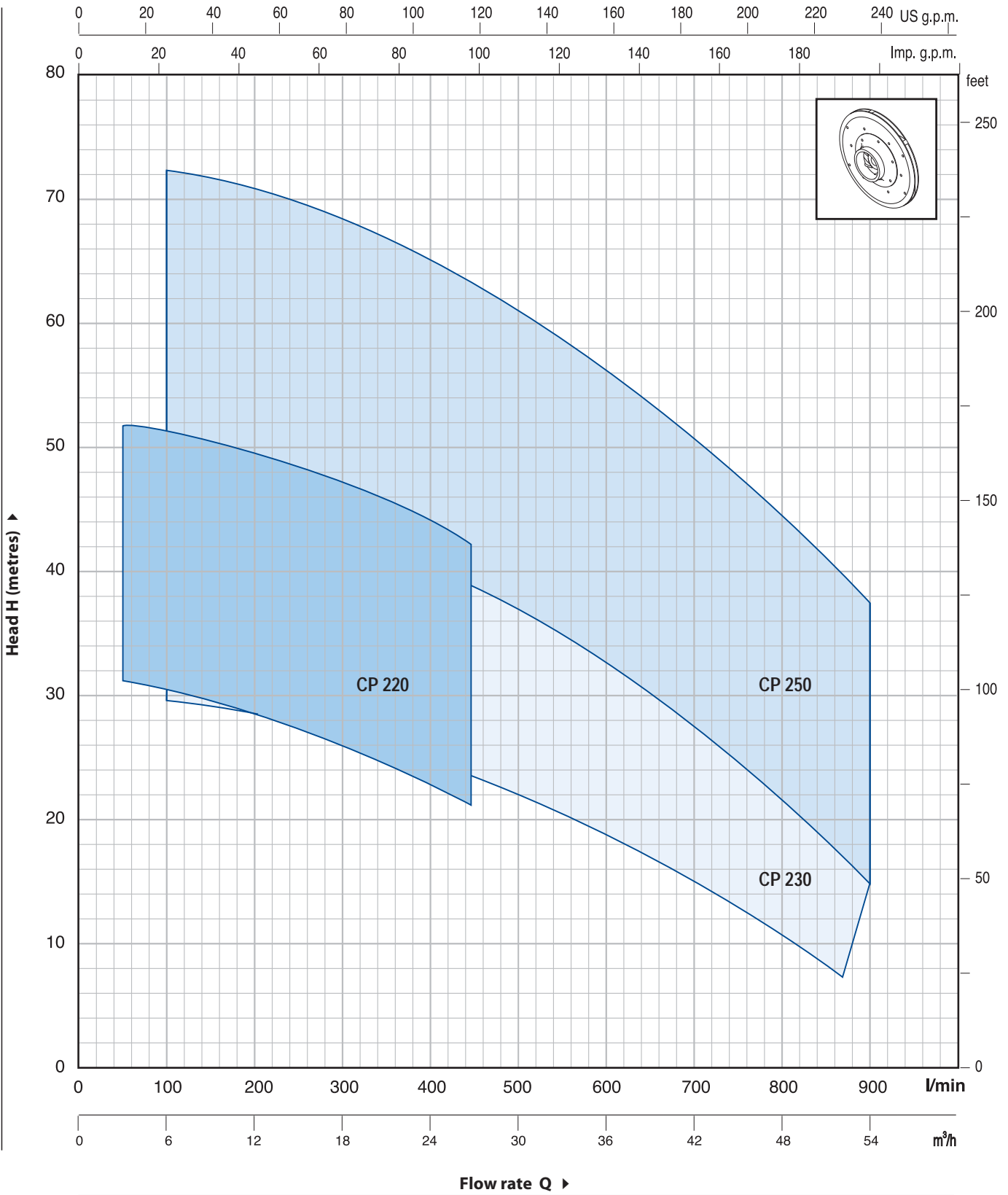

CP 220

CHARACTERISTIC CURVES AND PERFORMANCE DATA

50 Hz n= 2900 1/min HS= 0 m

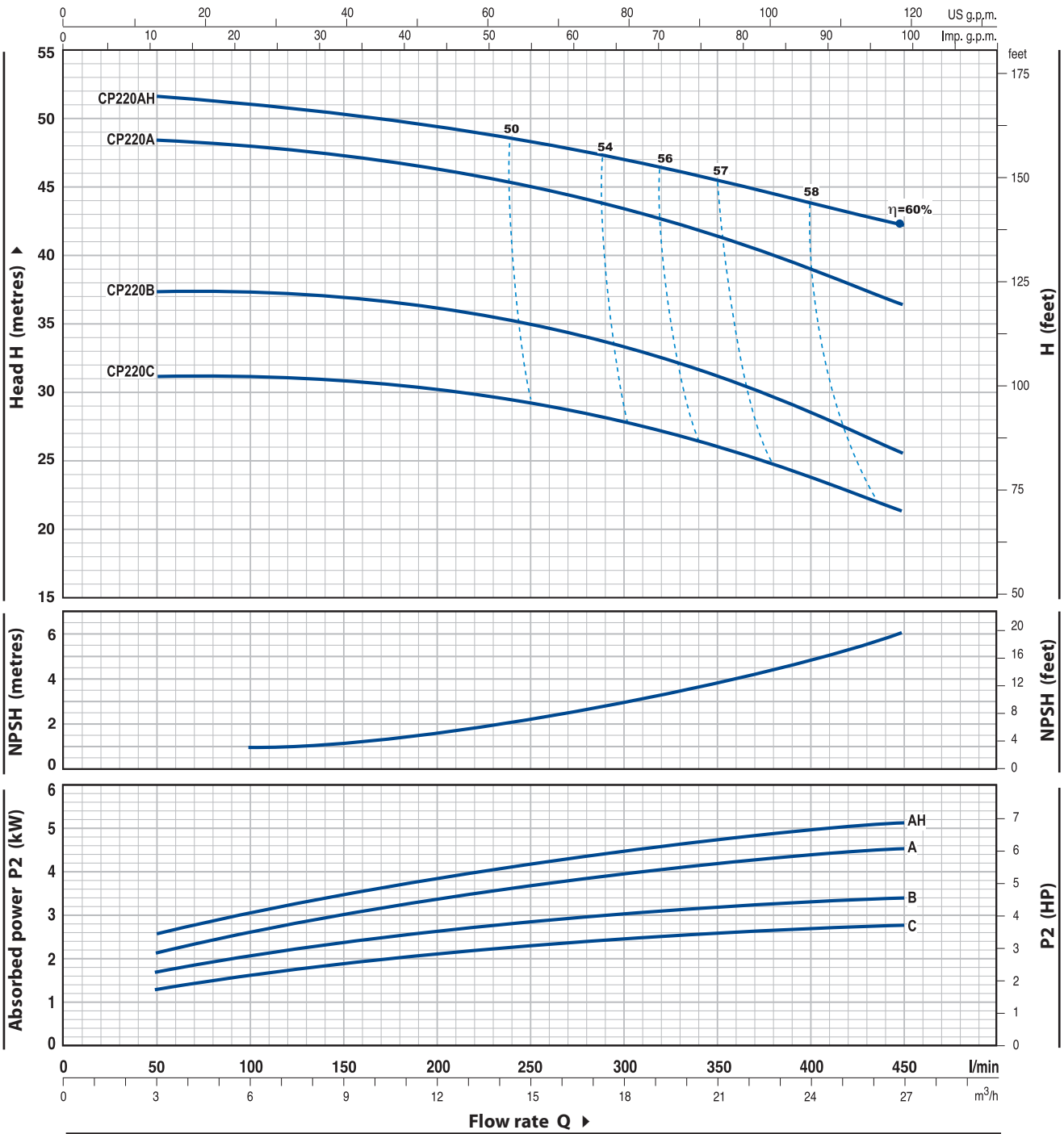

MODEL		POWER		Q	Flow rate						
Single-phase	Three-phase	kW	HP		m³/h	0	3	6	12	18	24
	CP 220C	2.2	3	H metres	0	50	100	200	300	400	450
-	CP 220B	3	4		32	31.5	31	30	28	24	21
-	CP 220A	4	5.5		38	37.5	37	36	33.5	29	25
-	CP 220AH	5.5	7.5		49	48.5	48	46	43.5	39.5	36
					52	51.5	51	49	47	44	42

Q = Flow rate H = Total manometric head HS = Suction height

Tolerance of characteristic curves in compliance with EN ISO 9906 App. A.

CHARACTERISTIC CURVES AND PERFORMANCE DATA

50 Hz n= 2900 1/min HS= 0 m

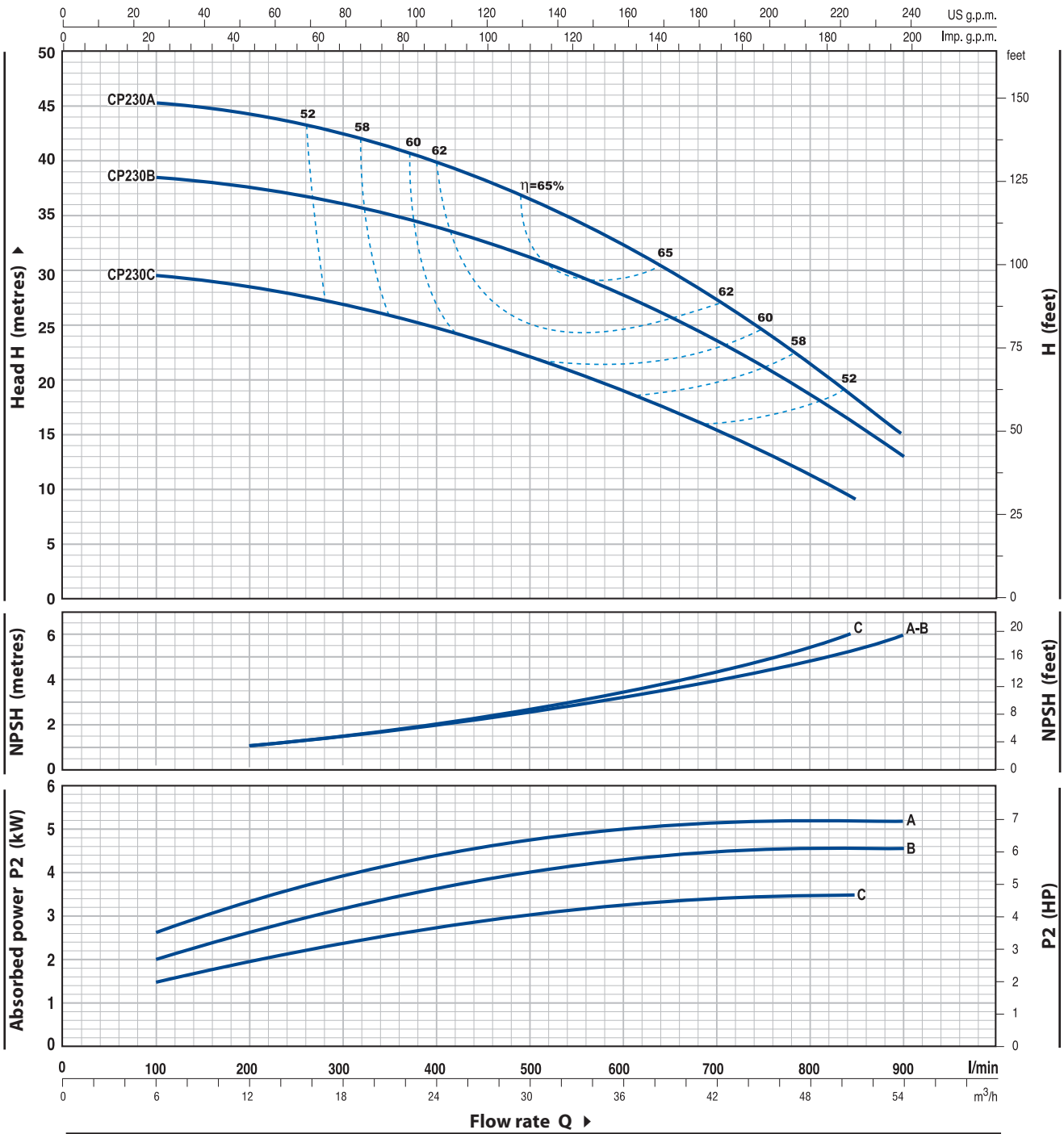

MODEL	POWER		Q	Flow rate												
	kW	HP		m³/h	0	6	12	18	24	30	36	42	48	51	54	
Three-phase			l/min	0	100	200	300	400	500	600	700	800	850	900		
CP 230C	3	4	H metres	30	29.5	28.5	27	25	22	19.5	15.5	11.5	9			
CP 230B	4	5.5		39	38.5	38	36	34	31	28	24	18.5	15	13		
CP 230A	5.5	7.5		46	45.5	44.5	42	40	37	32.5	27.5	21.5	18	15		

Q = Flow rate H = Total manometric head HS = Suction height

Tolerance of characteristic curves in compliance with EN ISO 9906 App. A.

CP 250

CHARACTERISTIC CURVES AND PERFORMANCE DATA

50 Hz n= 2900 1/min HS= 0 m

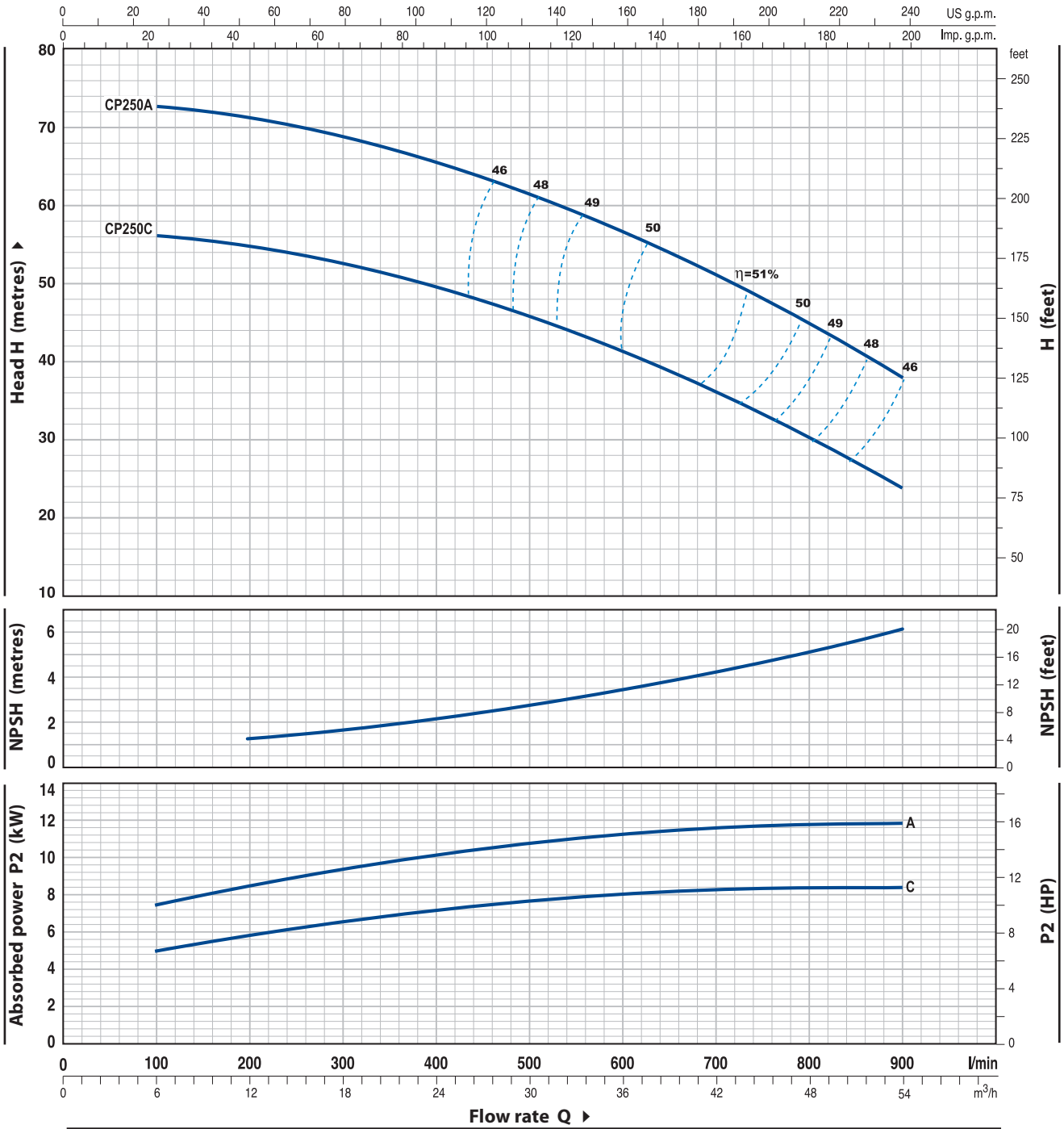

MODEL	POWER		Q	Flow rate												
	kW	HP		m ³ /h	0	6	12	18	24	30	36	42	48	54		
Three-phase			l/min	0	100	200	300	400	500	600	700	800	900			
CP 250C	7.5	10	H metres	57	56	54.5	52.5	49.5	46	41.5	35.5	30	24			
CP 250A	11	15		74	73	71	68	65	61	57	51	45	37			

Q = Flow rate H = Total manometric head HS = Suction height

Tolerance of characteristic curves in compliance with EN ISO 9906 App. A.

CHARACTERISTIC CURVES AND PERFORMANCE DATA

50 Hz n= 2900 1/min HS= 0 m

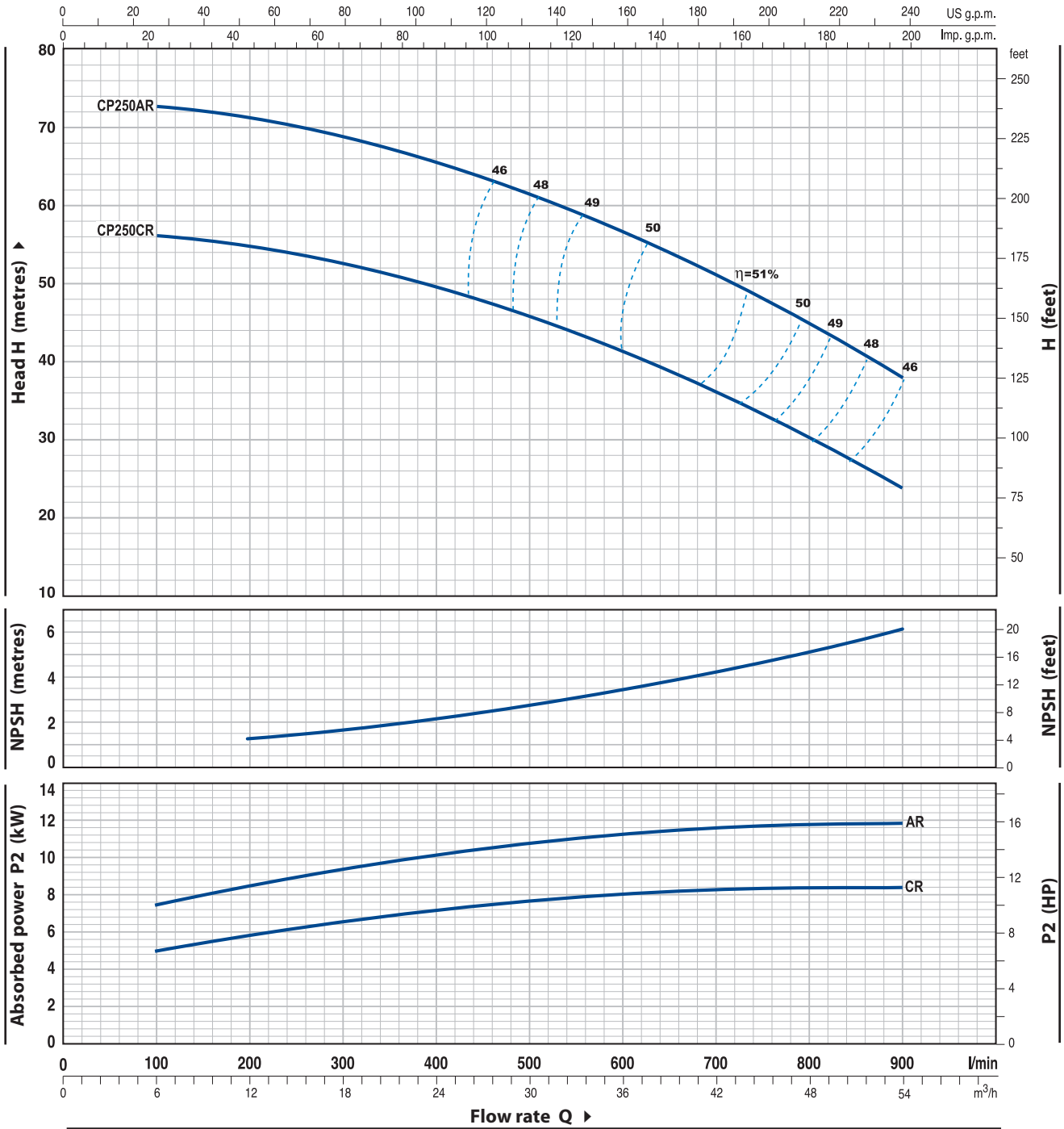

MODEL	POWER		Q	Flow rate												
	kW	HP		m ³ /h	0	6	12	18	24	30	36	42	48	54		
Three-phase			l/min	0	100	200	300	400	500	600	700	800	900			
CP 250CR	7.5	10	H metres	57	56	54.5	52.5	49.5	46	41.5	35.5	30	24			
CP 250AR	11	15		74	73	71	68	65	61	57	51	45	37			

Q = Flow rate H = Total manometric head HS = Suction height

Tolerance of characteristic curves in compliance with EN ISO 9906 App. A.

POS.	COMPONENT	CONSTRUCTION CHARACTERISTICS					
1	PUMP BODY	Cast iron, complete with threaded ports in compliance with ISO 228/1					
2	BODY BACKPLATE	Cast iron					
3	IMPELLER	Brass for CP 220, CP 230 Cast iron for CP 250					
4	MOTOR SHAFT	Stainless steel EN 10088-3 - 1.4104					
5	MECHANICAL SEAL	<i>Pump</i>	<i>Seal</i>	<i>Shaft</i>	<i>Materials</i>		
		<i>Model</i>	<i>Model</i>	<i>Diameter</i>	<i>Stationary ring</i>	<i>Rotational ring</i>	<i>Elastomer</i>
		CP 220C-B CP 230C	FN-20	Ø 20 mm	Graphite	Ceramic	NBR
		CP 220A-AH CP 230B-A CP 250C-CR	FN-24	Ø 24 mm	Graphite	Ceramic	NBR
		CP 250A-AR	FN-32 NU	Ø 32 mm	Graphite	Ceramic	NBR
6	BEARINGS	<i>Pump</i>	<i>Model</i>				
		CP 220C	6206 ZZ - C3 / 6204 ZZ				
		CPm 220C					
		CP 220B CP 230C	6206 ZZ - C3 / 6205 ZZ				
		CP 220A-AH CP 230B-A CP 250C-CR	6307 ZZ - C3 / 6206 ZZ - C3				
		CP 250A-AR	6310 ZZ - C3 / 6308 ZZ - C3				
7	CAPACITOR	<i>Pump</i>	<i>Capacitance</i>				
		<i>Single-phase</i>	<i>(230 V or 240 V)</i>				
		CPm 220C	70 µF 450 VL				
8	ELECTRIC MOTOR	CPm: single-phase 230 V - 50 Hz. CP: three-phase 230/400 V - 50 Hz up to 4 kW. 400/690 V - 50 Hz from 5.5 to 11 kW. ➔ Pumps fitted with the three-phase motor option offer IE2 (IEC 60034-30) class high performance – Insulation: F class. – Protection: IP 44.					

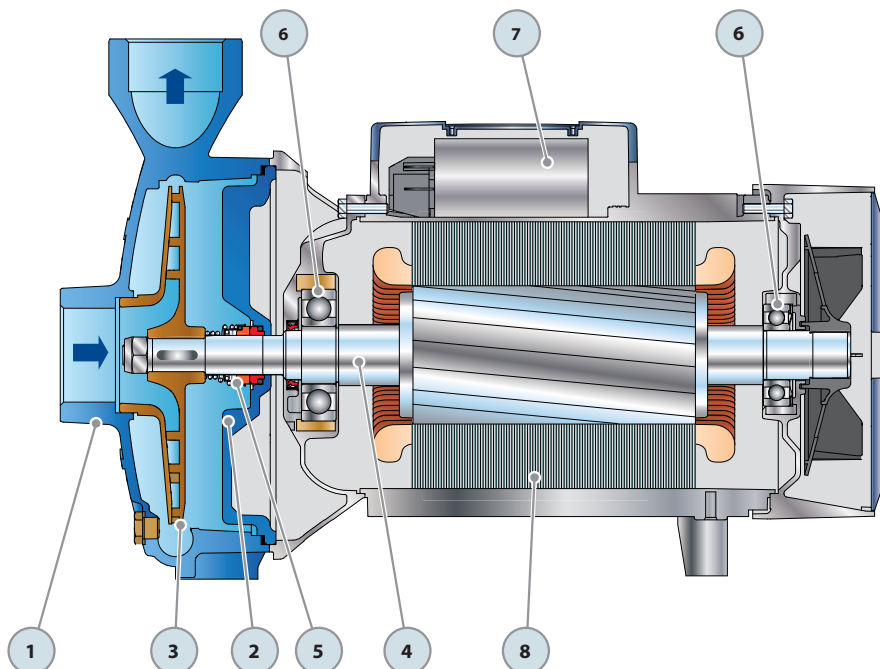

DIMENSIONS AND WEIGHT

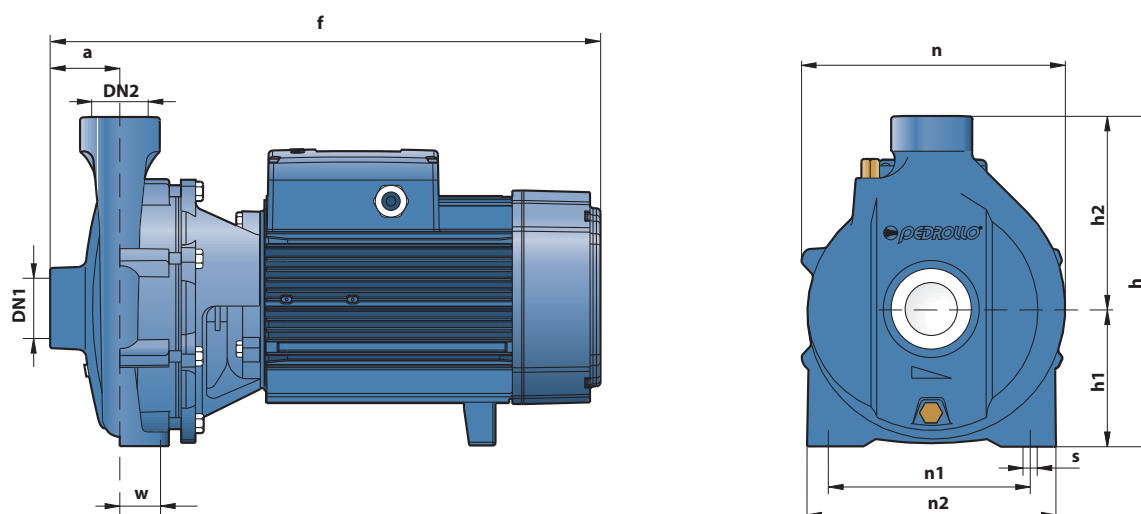

MODEL		PORTS		DIMENSIONS mm										kg			
Single-phase	Three-phase	DN1	DN2	a	f	h	h1	h2	n	n1	n2	w	s	1~	3~		
CPm 220C	CP 220C	2"	2"	70	426/409	315	132	183	255	170	230	40	14	31.5	28.5		
-	CP 220B				426											-	31.9
-	CP 220A				460											-	41.0
-	CP 220AH				505											-	46.0
-	CP 230C				426											-	31.5
-	CP 230B				460											-	41.0
-	CP 230A				505											-	46.0
-	CP 250C				507											-	74.0
-	CP 250A				571											-	103.0
-	CP 250CR				534											-	78.0
-	CP 250AR	598	-	107.0													
-	-	4"	3"	92	534	392	160	232	322	230	294	45	-	-			

ABSORPTION

MODEL	VOLTAGE (single-phase)	
Single-phase	230 V	240 V
CPm 220C	15.8 A	15.0 A

MODEL	VOLTAGE (three-phase)					
Three-phase	230 V	400 V	690 V	240 V	415 V	720 V
CP 220C	11.4 A	6.6 A	3.8 A	10.7 A	6.2 A	3.6 A
CP 220B	12.6 A	7.3 A	4.2 A	12.0 A	7.0 A	4.0 A
CP 220A	17.0 A	9.8 A	5.7 A	16.5 A	9.5 A	5.5 A
CP 220AH	20.0 A	11.5 A	6.7 A	21.0 A	12.0 A	6.9 A
CP 230C	13.2 A	7.6 A	4.4 A	11.1 A	6.4 A	3.7 A
CP 230B	16.8 A	9.7 A	5.6 A	16.2 A	9.4 A	5.4 A
CP 230A	20.0 A	11.5 A	6.7 A	19.2 A	11.0 A	6.4 A
CP 250C-CR	28.6 A	16.5 A	9.5 A	27.5 A	16.0 A	9.3 A
CP 250A-AR	40.8 A	23.6 A	13.7 A	40.8 A	23.6 A	13.7 A

PALLETIZATION

MODEL		GROUPAGE				CONTAINER			
Single-phase	Three-phase	n° pumps	H (mm)	kg		n° pumps	H (mm)	kg	
				1~	3~			1~	3~
CPm 220C	CP 220C	18	1220	590	530	24	1580	780	700
-	CP 220B	18	1180	-	600	24	1520	-	790
-	CP 220A	18	1430	-	760	24	1860	-	1000
-	CP 220AH	12	1430	-	570	16	1860	-	760
-	CP 230C	18	1200	-	590	24	1550	-	780
-	CP 230B	18	1430	-	760	24	1860	-	1000
-	CP 230A	12	1430	-	570	16	1860	-	760
-	CP 250C	6	1180	-	460	-	-	-	-
-	CP 250A	6	1180	-	640	-	-	-	-
-	CP 250CR	6	1180	-	490	-	-	-	-
-	CP 250AR	6	1180	-	660	-	-	-	-

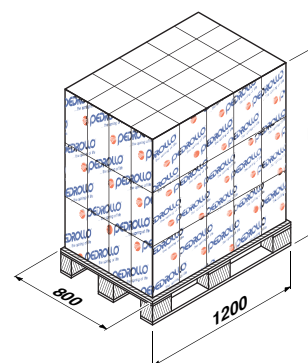



PERFORMANCE RANGE

- Flow rate up to **250 l/min** (15 m³/h)
- Head up to **57 m**

APPLICATION LIMITS

- Manometric suction lift up to **7 m**
- Liquid temperature between **-10 °C** and **+90 °C**
- Ambient temperature between **-10 °C** and **+40 °C**
- Max. working pressure **10 bar**
- Continuous service **S1**

CONSTRUCTION AND SAFETY STANDARDS

EN 60034-1
IEC 60034-1
CEI 2-3



CERTIFICATIONS



INSTALLATION AND USE

Suitable for use with clean water and liquids that are not chemically aggressive towards the materials from which the pump is made. The pumps in this series are specifically intended for use in the civil, industrial and agricultural sectors where their overriding characteristics of sturdiness and reliability are best appreciated. The pump should be installed in an enclosed environment, or at least sheltered from inclement weather.

OPTIONALS AVAILABLE ON REQUEST

- Special mechanical seal
- Other voltages or 60 Hz frequency

GUARANTEE

1 year subject to terms and conditions

CHARACTERISTIC CURVES AND PERFORMANCE DATA

50 Hz n= 2900 1/min HS= 0 m

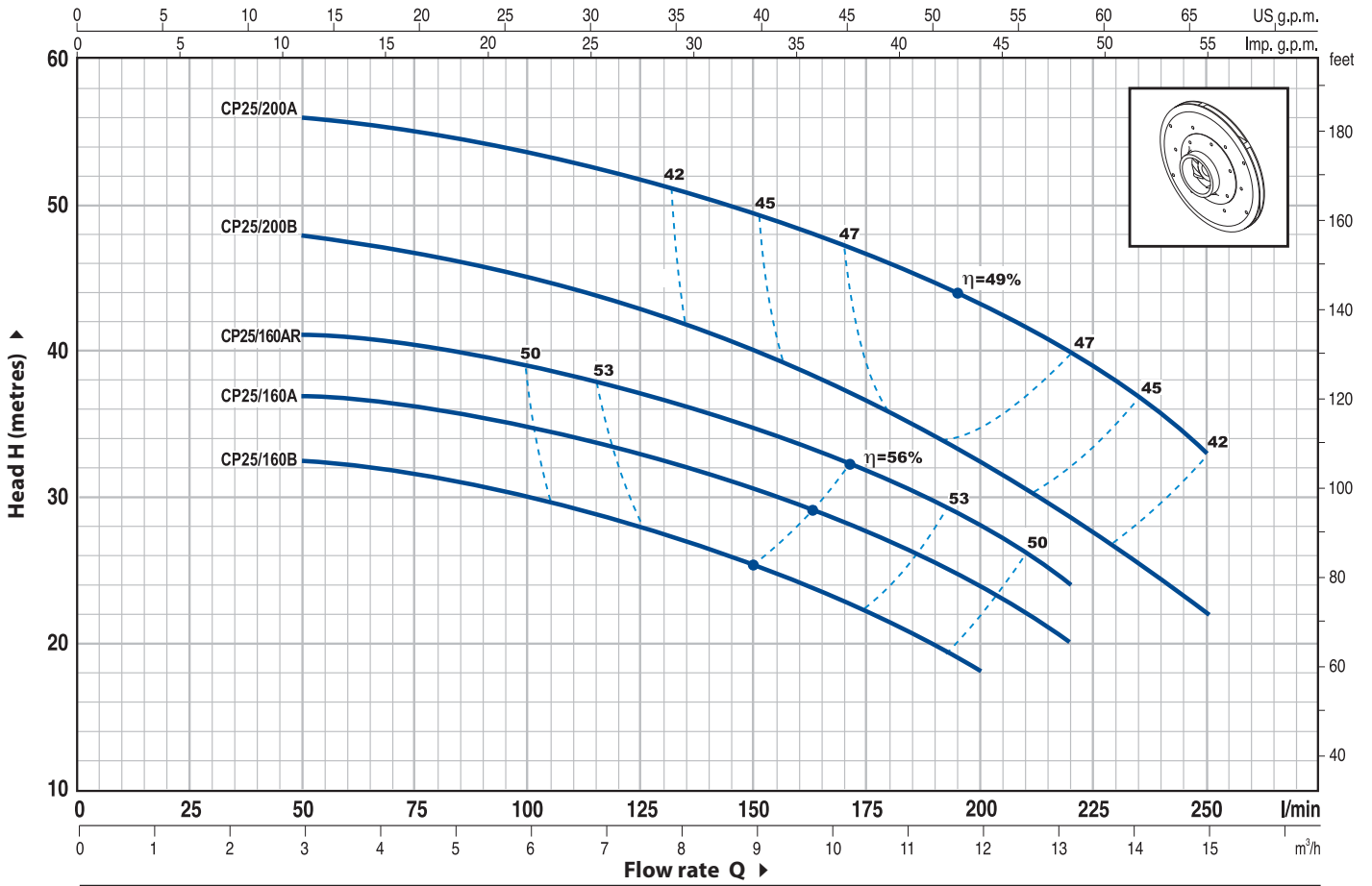

MODEL		POWER		Q	H metres																		
Single-phase	Three-phase	kW	HP		0	3.0	3.6	4.2	4.8	5.4	6.0	6.6	7.5	8.4	9.6	10.8	12.0	13.2	15.0				
				l/min	0	50	60	70	80	90	100	110	125	140	160	180	200	220	250				
CPm 25/160B	CP 25/160B	1.1	1.5	H metres	33	32.5	32	31.5	31	30.5	30	29	28	26.5	24	21.5	18						
CPm 25/160A	CP 25/160A	1.5	2		38	37	36.8	36.5	36	35.5	35	34	33	31.5	29.5	27	24	20					
-	CP 25/160AR	2.2	3		42	41	41	40.5	40	39.5	39	38	37	36	34	31	28	24					
CPm 25/200B	CP 25/200B	2.2	3		49	48	47.5	47	46.5	45.5	45	44	43	41	38.5	36	32	28	22				
-	CP 25/200A	3	4		57	56	55.8	55.5	55	54.5	53.5	53	52	50.5	48.5	46	43.5	40	33				

Q = Flow rate H = Total manometric head HS = Suction height

Tolerance of characteristic curves in compliance with EN ISO 9906 App. A.

POS.	COMPONENT	CONSTRUCTION CHARACTERISTICS					
1	PUMP BODY	Cast iron, made to EN 733 standards, complete with threaded ports in compliance with ISO 228/1					
2	BODY BACKPLATE	Cast iron					
3	IMPELLER	Brass					
4	MOTOR SHAFT	Stainless steel EN 10088-3 - 1.4104					
5	MECHANICAL SEAL	<i>Pump</i>	<i>Seal</i>	<i>Shaft</i>	<i>Materials</i>		
		<i>Model</i>	<i>Model</i>	<i>Diameter</i>	<i>Stationary ring</i>	<i>Rotational ring</i>	<i>Elastomer</i>
		CP 25/160	FN-18	Ø 18 mm	Graphite	Ceramic	NBR
		CP 25/200	FN-24	Ø 24 mm	Graphite	Ceramic	NBR
6	BEARINGS	<i>Pump</i>	<i>Model</i>				
		CP 25/160	6204 ZZ / 6204 ZZ				
		CP 25/200	6206 ZZ - C3 / 6205 ZZ				
7	CAPACITOR	<i>Pump</i>	<i>Capacitance</i>				
		<i>Single-phase</i>	<i>(230 V or 240 V)</i>		<i>(110 V)</i>		
		CPm 25/160B	31.5 µF 450 VL		60 µF 250 VL		
		CPm 25/160A	45 µF 450 VL		80 µF 250 VL		
		CPm 25/200B	70 µF 450 VL		-		
8	ELECTRIC MOTOR	<p>CPm: single-phase 230 V - 50 Hz with thermal overload protector built-in to the winding (up to 1.5 kW). CP: three-phase 230/400 V - 50 Hz.</p> <p>⇒ Pumps fitted with the three-phase motor option offer IE2 (IEC 60034-30) class high performance</p> <p>- Insulation: F class. - Protection: IP 44.</p>					

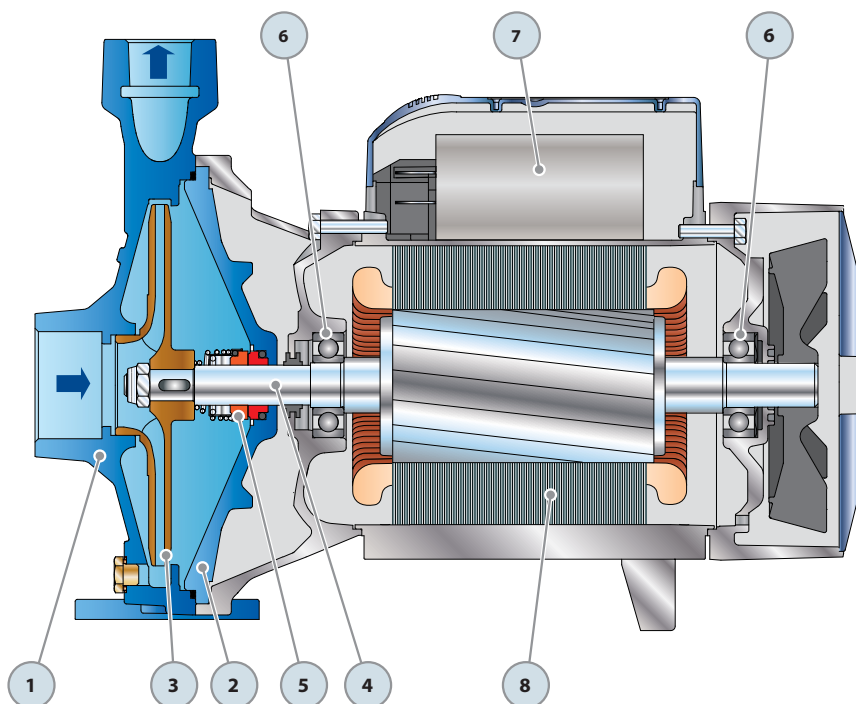

DIMENSIONS AND WEIGHT

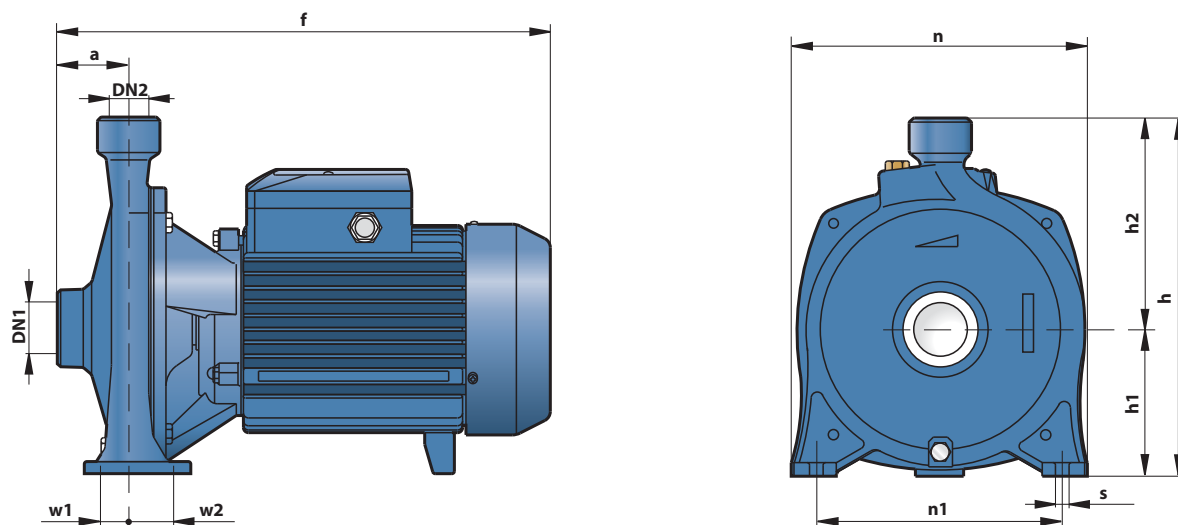

MODEL		PORTS		DIMENSIONS mm										kg	
Single-phase	Three-phase	DN1	DN2	a	f	h	h1	h2	n	n1	w1	w2	s	1~	3~
CPm 25/160B	CP 25/160B	1½"	1"	56	375	260	105	155	206	150	27.5	27.5	10	20.0	18.0
CPm 25/160A	CP 25/160A													21.3	21.3
-	CP 25/160AR													-	21.3
CPm 25/200B	CP 25/200B			60	390/365	305	125	180	252	210	23.5	39.5	11	28.5	30.7
-	CP 25/200A				390									-	30.9

ABSORPTION

MODEL	VOLTAGE (single-phase)		
	230 V	240 V	110 V
CPm 25/160B	8.5 A	7.8 A	17.0 A
CPm 25/160A	9.8 A	8.9 A	19.6 A
CPm 25/200B	13.4 A	13.0 A	-

MODEL	VOLTAGE (three-phase)					
	230 V	400 V	690 V	240 V	415 V	720 V
CP 25/160B	5.7 A	3.3 A	1.9 A	5.2 A	3.0 A	1.7 A
CP 25/160A	7.3 A	4.2 A	2.4 A	6.7 A	3.9 A	2.3 A
CP 25/160AR	8.9 A	5.1 A	3.0 A	8.3 A	4.8 A	2.8 A
CP 25/200B	10.5 A	6.0 A	3.5 A	9.6 A	5.6 A	3.3 A
CP 25/200A	12.4 A	7.2 A	4.2 A	11.0 A	6.4 A	3.7 A

PALLETIZATION

MODEL		GROUPAGE				CONTAINER			
Single-phase	Three-phase	n° pumps	H (mm)	kg		n° pumps	H (mm)	kg	
				1~	3~			1~	3~
CPm 25/160B	CP 25/160B	50	1560	1020	920	70	2130	1420	1280
CPm 25/160A	CP 25/160A	50	1560	1090	1040	70	2130	1510	1440
-	CP 25/160AR	50	1560	-	1090	70	2130	-	1510
CPm 25/200B	CP 25/200B	18	1190	530	570	-	-	-	-
-	CP 25/200A	18	1210	-	580	-	-	-	-

